

Table of Contents

1.0	Table of Contents	1.360	Concrete protective plate for distribution shaft
		1.365	Insulation material, PE foam PUR foam containers
1.1	System description	1.370	Screwed connectors, outer thread, weld end
1.100	System description (general)	1.375	Screwed connectors, coupling: equal, reduced
1.105	System description (data)	1.380	Compression connectors, thread, weld end with sliding sleeve
1.106	System description (data)	1.385	Compression connectors, coupling, angle 90° with sliding sleeve
1.110	Long-term behaviour/lifetime calculation	1.390	Compression T-piece, with sliding sleeve, heating 6 bar
1.115	CALPEX PUR-KING UNO range, heating 6 bar – structure, dimensions, materials, weights and delivery lengths	1.395	Compression T-piece, with sliding sleeve, sanitary 10 bar
1.116	CALPEX PUR-KING DUO range, heating 6 bar – structure, dimensions, materials, weights and delivery lengths	1.400	Electro-fusion joint
1.120	CALPEX PUR-KING UNO/DUO range, sanitary 10 bar – structure, dimensions, materials, weights and delivery lengths	1.405	End cap, standard, shrinkable
1.125	CALPEX QUADRIGA range, heating 6 bar, sanitary 10 bar – structure, dimensions, materials, weights and delivery lengths	1.410	Wall sealing ring, for wall openings
		1.415	Building entry, wall opening/core bore
		1.420	Wall seal, core bores/cement pipe liners
		1.425	Building entry, core bores/cement pipe liners
1.2	Planning, design engineering	1.5	Underground construction, installation
1.200	Pressure loss chart CALPEX PUR-KING, heating, 6 bar	1.500	Pipe routing
1.205	Pressure loss chart CALPEX SANITARY, sanitary, 10 bar	1.505	Trench dimensions
1.210	Heat loss CALPEX PUR-KING, heating, 6 bar	1.510	Pipe warning tape, laying tools
1.215	Heat loss CALPEX SANITARY, sanitary, 10 bar	1.515	Connection (rigid/flexible), CALPEX plastic casing pipe
1.220	Heat loss CALPEX QUADRIGA, heating 6 bar, sanitary 10 bar	1.520	House entry, screwed connector, shaft entry, fixed point forces
1.225	Planning and connection technology, heating strip, sanitary, 10 bar	1.525	House connection, compression joint, shaft entry, fixed point forces
1.3	Components	1.530	Installation of house entry
1.300	House entry bend 90° CALPEX PUR-KING, heating 6 bar, UNO	1.535	Installation tool, general and for screwed connector
1.301	House entry bend 90° CALPEX PUR-KING, heating 6 bar, DUO	1.540	Installation tool, for joint with sliding sleeves
1.305	House entry bend 90° CALPEX SANITARY, sanitary 10 bar, UNO and DUO	1.545	Heating strip CALPEX SANITARY, sanitary, 10 bar, drawing in, sensor, joint
1.310	House entry bend 90° CALPEX QUADRIGA, heating 6 bar, sanitary 10 bar		
1.315	CALPEX L-shell		
1.316	CALPEX Big L-shell		
1.320	Joint (PE-HD shrink sleeve)		
1.325	CALPEX I-shell		
1.326	CALPEX Big I-shell		
1.330	CALPEX T-shell		
1.335	CALPEX Big T-shell		
1.336	CALPEX-PE-T-Shell		
1.340	T-joint		
1.345	Y-pipe CALPEX PUR-KING, heating, 6 bar		
1.350	Distribution chamber		
1.355	Distribution chamber, installation		

System description

1. General

CALPEX is the protected name for a flexible pipe system of Brugg Pipesystems, especially for the low-temperature range and is produced according to the current standard (EN 15632-1/-2). CALPEX PUR-KING, the district heating pipe, and CALPEX SANITARY, the service water pipe, are intended for use in small and medium-sized district and local heating networks as well as in industry and agriculture, in drinking water supplies, sewage systems, chillers and in swimming pool technology.

The CALPEX systems consist of a carrier pipe made of cross-linked polyethylene PEXa and are equipped with an organic oxygen diffusion barrier (EVOH).

The carrier pipe was selected or integrated into the standards because it has excellent thermal and mechanical properties. The corrosion-resistant, chemically resistant material is very robust and can very easily be processed by hand.

The thermal insulation of CALPEX PUR-KING consists of a patented flexible polyurethane rigid foam with excellent thermal insulation properties. This insulating material is produced by a chemical reaction. CALPEX PUR-KING has an extremely closed-cell structure, as a result of which its thermal insulation is improved considerably and remains stable for decades. CALPEX is free of harmful substances and therefore extremely environmentally friendly.

During the formation of the foam, the carrier pipes are wetted very effectively by it, resulting in a firm adhesion and a force-locking bond. The physical properties of the PEXa pipe combined with the insulation bond allow installation without having to take thermal expansion into account.

The ability to bend the CALPEX systems allows them to be adapted to all conditions along the pipe route with ease. Existing supply lines can be crossed by going under or over them; obstacles can easily be bypassed. With CALPEX systems, users can choose the shortest pipe route without the restrictions required by the classical method of pipe construction.

The CALPEX systems are delivered to the construction site in the desired length, in endless rings, or on a cable drum. Long delivery lengths enable pipes to be laid in the ground largely without joints. This means that the pipe trench can be considerably narrower. This allows considerable savings to be made in civil engineering work. This applies in particular to DUO lines.

If one also considers the very short installation time, the CALPEX systems are not only a technically perfect solution, but also the key to the time and cost-saving creation of district heating or service water networks due to the reduced amount of coordination work required on site and the quick and easy installation.

Assembling the connection pieces could hardly be easier. With conventional screw connections, press fittings or electrofusion couplers, the connections are quickly and safely installed. The wide range of accessories ensures that solutions can be chosen for every possible situation.

2. Range of applications

Heating, pipe series 5 (SDR 11):

Max. temp. for continuous operation T_{Bmax} : 80 °C
 Max. permitted operating temp. T_{max} : 95 °C (fluctuating)
 Max. permitted operating pressure p: 6 bar

see sheet CPX 1.110

Sanitary, pipe series 3.2 (SDR 7.4):

Max. temp. for continuous operation T_{Bmax} : 80 °C
 Max. permitted operating temp. T_{max} : 95 °C (fluctuating)
 Max. permitted operating pressure p: 10 bar

see sheet CPX 1.110

System description

1. Bonded system

Requirements: Factory insulated, flexible pipe systems according EN 15632-1/-2
 Fire behaviour: Building material class B2 (normally inflammable) according to DIN 4102

2. Carrier pipe

Materials Basic material: High-density polyethylene (PE-HD), peroxide cross-linked (PEXa), colour: natural
 Bonding agent PE-modified, heat-stabilized, colour: red (heating), silver (sanitary)
 Oxygen barrier layer Ethylene / vinyl alcohol (EVOH), heat-stabilized, colour: natural
 Requirements As per DIN 16892 / DIN 16893 and E DIN EN 12318-2, pipes in series 3.2 as per DVGW worksheet W 544
 Impermeability to oxygen As per DIN 4729 at 40 °C, oxygen permeability based on the interior pipe volume as per DIN 4726 from $\leq 0.10 \text{ g}/(\text{m}^3 \times \text{d})$
 Pipe series DIN 16893 Series 5 (SDR 11): for CALPEX PUR-KING (with EVOH barrier)
 Series 3.2 (SDR 7.4): for CALPEX SANITARY (with EVOH barrier)
 Long-term behaviour See catalog sheet CPX 1.110
 Properties Unaffected by aggressive water; low pressure losses; very good chemical and mechanical resistance (DIN 8075 sheet 1)

PEXa carrier pipe	Reference temperature °C	Value	Test standard
Density	-	932 - 935 kg/m ³	ISO 1183
Thermal conductivity	-	0.38 W/mK	in Anlehnung an ASTM C 1113
Tensile strength	20	min. 18 N/mm ²	ISO 6259
Tensile strength	80	min. 8 N/mm ²	ISO 6259
Linear expansion coefficient	20	$1.4 \cdot 10^{-4} \text{ 1/K}$	-
Linear expansion coefficient	100	$2.0 \cdot 10^{-4} \text{ 1/K}$	-
Crystallite melting range	-	128 - 134 °C	-
Chem. resistance	20 / 40 / 60	-	DIN 8075 B.1

3. Thermal insulation

Materials: **CALPEX PUR-KING (heating 6 bar)**
 CFC-free, cyclopentane-blown polyurethane foam (PUR)
CALPEX SANITARY (sanitary 10 bar)
 CFC-free, 100 % CO₂-blown polyurethane foam (PUR)

PUR insulation	Reference temperature °C	CALPEX PUR-KING	CALPEX SANITARY	Test standard
Density	-	> 50 kg/m ³	> 50 kg/m ³	EN 253
Axial shear strength	-	≥ 90 kPa	-	EN 15632-2
Thermal conductivity flexible systems	50	≤ 0.0199 W/mK	≤ 0.0234 W/mK	EN 253 and ISO 8497
Thermal conductivity rigid systems	50	≤ 0.0260 W/mK	-	EN 253 and ISO 8497
Percentage of closed cells	-	≥ 88 %	≥ 90 %	EN 253
Water absorption	100	≤ 10 %	≤ 10 %	EN 15632-1

4. Protective casing

Materials: linear polyethylene, low density (LLD-PE), seamlessly extruded
 Purpose: mechanical protection and moisture resistance

LLD-PE protective casing	Reference temperature °C	Value	Test standard
Density	-	918 - 922 kg/m ³	ASTM D792
Thermal conductivity	-	0.33 W/mK	DIN 52612
Graphite content	-	> 2%	EN 15632-1

Long-term behaviour

Lifetime calculation

Operating temperature: °C	CALPEX PUR-KING (pipe series 5 / SDR 11) Operating pressure (bar)					CALPEX SANITARY (pipe series 3.2 / SDR 7.4) Operating pressure (bar)				
	1 year	5 year	10 year	25 year	50 year	1 year	5 year	10 year	25 year	50 year
10	17.9	17.5	17.4	17.2	17.1	28.3	27.8	27.6	27.3	27.1
20	15.8	15.5	15.4	15.2	15.1	25.1	24.6	24.4	24.2	24.0
30	14.0	13.8	13.7	13.5	13.4	22.3	21.9	21.7	21.4	21.3
40	12.5	12.2	12.1	12.0	11.9	19.8	19.4	19.3	19.1	18.9
50	11.1	10.9	10.8	10.7	10.6	17.7	17.3	17.2	17.0	16.8
60	9.9	9.7	9.7	9.5	9.5	15.8	15.5	15.3	15.2	15.0
70	8.9	8.7	8.6	8.5	8.5	14.1	13.8	13.7	13.6	13.4
80	8.0	7.8	7.7	7.6	-	12.7	12.4	12.3	12.1	-
90	7.2	7.0	6.9	-	-	11.4	11.1	11.0	-	-
95	6.8	6.6	6.6	-	-	10.8	10.6	10.5	-	-

1 MPA = 10 bar

Long-term behaviour: (table)

The values have a safety factor of 1.25 and are based on a series of measurements covering an average of 32,000 hours. They can be compared with Table 5 as per DIN 16893. All values have been tested and confirmed by the competent organizations in various countries. The max. operating temperature is 95 °C but considers a short-term over temperature (fault temperature) of 110 °C.

A typical fluctuating temperature distribution for the flow in a district heating system gives an average temperature/year of approx. 66 °C.

Lifetime calculation using Miner's Rule

Lifetime calculation for fluctuating operating temperatures will be calculated acc. EN ISO 13760.

Example of application

The basis is a typical temperature collective over one year, with fluctuating operation. (gem. EN 15632-2)

1 year = 365 days = 8760 hours.

Operating Temperature °C	Example 1 Annual Operating time h	Example 2 Annual Operating time h	Example 3 Annual Operating time h
95	3,3	0	0
90	292	50	50
85	0	100	1000
80	8468	200	3450
75	0	2000	1000
70	0	2410	0
65	0	4000	0
60	0	0	0
total	8763,3	8760	5500

Example 1: life time of 30 years

Example 2: life time of 50 years

Example 3: life time of 40 years

CALPEX PUR-KING

CALPEX PUR-KING UNO (heating, 6 bar)

CALPEX PUR-KING

in coils:

Dimensions:

CPX Ø 76 - 202 mm

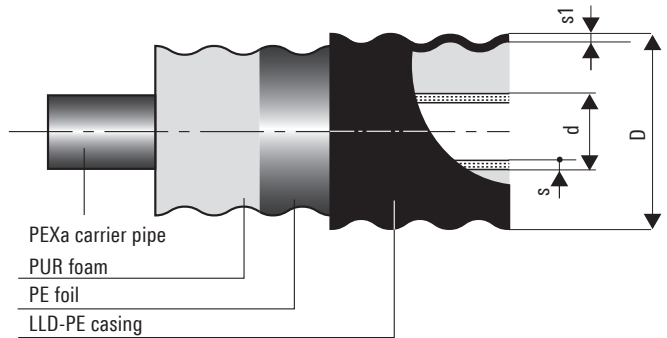
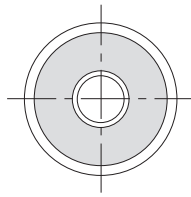

CALPEX PUR-KING in straight

lengths:

Dimensions:

CPX Ø 250 mm

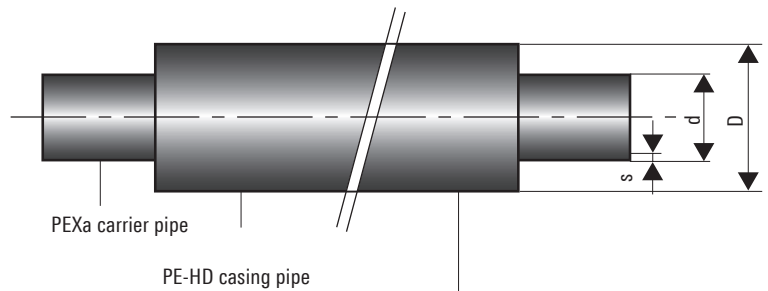
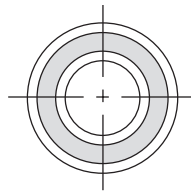

CALPEX PUR-KING heating, 6 bar, UNO

Type	PEX carrier pipe d x s mm	Nominal diameter		Outer casing D x s1 mm	Minimum bending radius m	Volume Carrier pipe l/m	Weight kg/m	Maximum delivery lengths*	
		DN	Inches "					Jumbo coil m	Maxi coil m
25/ 76	25 x 2.3	20	¾	78 x 1.9	0.45	0.32	0.90	700	1000
25/ 91 PLUS				93 x 2.1	0.65	0.32	1.20	450	715
32/ 76	32 x 2.9	25	1	78 x 1.9	0.50	0.53	1.00	700	1000
32/ 91 PLUS				93 x 2.1	0.70	0.53	1.40	450	715
40/ 91	40 x 3.7	32	1¼	93 x 2.1	0.55	0.83	1.40	450	715
40/111 PLUS				113 x 2.3	0.75	0.83	1.70	300	450
50/111	50 x 4.6	40	1½	113 x 2.3	0.60	1.30	1.97	300	450
50/126 PLUS				128 x 2.7	0.80	1.30	2.40	192	291
63/126	63 x 5.8	50	2	128 x 2.7	0.65	2.07	2.60	192	291
63/142 PLUS				143 x 2.9	0.85	2.07	3.10	160	260
75/142	75 x 6.8	65	2½	143 x 2.9	0.70	2.96	3.39	160	260
75/162 PLUS				163 x 3.2	0.90	2.96	3.90	92	149
90/162	90 x 8.2	80	3	163 x 3.2	1.00	4.25	4.56	92	149
90/182 PLUS				183 x 3.3	1.20	4.25	4.80	52	86
110/162	110 x 10.0	100	4	163 x 3.2	1.10	6.36	5.70	92	149
110/182				183 x 3.3	1.20	6.36	6.60	52	86
110/202 PLUS**				202 x 3.3	1.40	6.36	6.80	46	80
125/182	125 x 11.4	125	5	183 x 3.3	1.30	8.20	7.20	52	86
125/202 PLUS**				202 x 3.3	1.50	8.20	7.80	46	80
140/202	140 x 12.7	125	5	202 x 3.3	1.40	10.31	8.40	46	80
160/250	160 x 14.6	150	6	250 x 3.9	-	13.43	11.80	12	12

* Supply as section length, as coils and on drums possible. The delivered coil length may vary (+/- 5%)

** Available on request

- We will produce different dimensions or special items on request.
- Larger or smaller delivery lengths can be supplied on drums if requested.
- Coil dimensions: **Jumbo coil** outer diameter 2800 mm x 800 mm (width)
Maxi coil outer diameter 2800 mm x 1200 mm (width)

When ordering at the construction site, please observe the total weight of the coil (unwinding equipment)

CALPEX PUR-KING range

CALPEX PUR-KING DUO (heating, 6 bar)

CALPEX PUR-KING

in coils:

Dimensions:

CPX Ø 76 - 202 mm

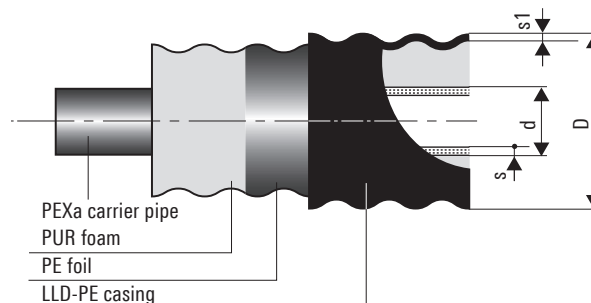
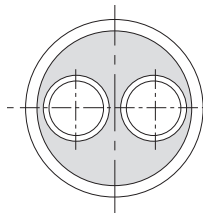

CALPEX PUR-KING heating, 6 bar, DUO

Type	PEX carrier pipe d x s mm	Nominal diameter		Outer casing D x s1 mm	Minimum bending radius m	Volume Carrier pipe l/m	Weight kg/m	Maximum delivery lengths*	
		DN	Inches "					Jumbo coil m	Maxi coil m
25 + 25/ 91	2 x 25 x 2.3	20 + 20	2 x ¾	93 x 2.1	0.55	2 x 0.32	1.34	450	715
25 + 25/111 PLUS				113 x 2.3	0.75	2 x 0.32	1.60	300	450
32 + 32/111	2 x 32 x 2.9	25 + 25	2 x 1	113 x 2.3	0.60	2 x 0.53	1.90	300	450
32 + 32/126 PLUS				128 x 2.7	0.80	2 x 0.53	2.30	192	291
40 + 40/126	2 x 40 x 3.7	32 + 32	2 x 1¼	128 x 2.7	0.65	2 x 0.83	2.50	192	291
40 + 40/142 PLUS				143 x 2.9	0.85	2 x 0.83	3.00	160	260
50 + 50/162	2 x 50 x 4.6	40 + 40	2 x 1½	163 x 3.2	1.10	2 x 1.30	4.00	92	149
50 + 50/182 PLUS				183 x 3.3	1.30	2 x 1.30	4.70	52	86
63 + 63/182	2 x 63 x 5.8	50 + 50	2 x 2	183 x 3.3	1.20	2 x 2.07	5.30	52	86
63 + 63/202 PLUS**				202 x 3.3	1.40	2 x 2.07	6.00	46	80
75 + 75/202**	2 x 75 x 6.8	65 + 65	2½ x 2½	202 x 3.3	1.40	2 x 2.96	6.90	46	80

* Supply as section length, as coils and on drums possible. The delivered coil length may vary (+/- 5%)

** Available on request

- We will produce different dimensions or special items on request.
- Larger or smaller delivery lengths can be supplied on drums if requested.
- Coil dimensions:
 - Jumbo coil** outer diameter 2800 mm x 800 mm (width)
 - Maxi coil** outer diameter 2800 mm x 1200 mm (width)

When ordering at the construction site, please observe the total weight of the coil (unwinding equipment)

CALPEX SANITARY range

CALPEX SANITARY UNO/DUO (sanitary 10 bar)

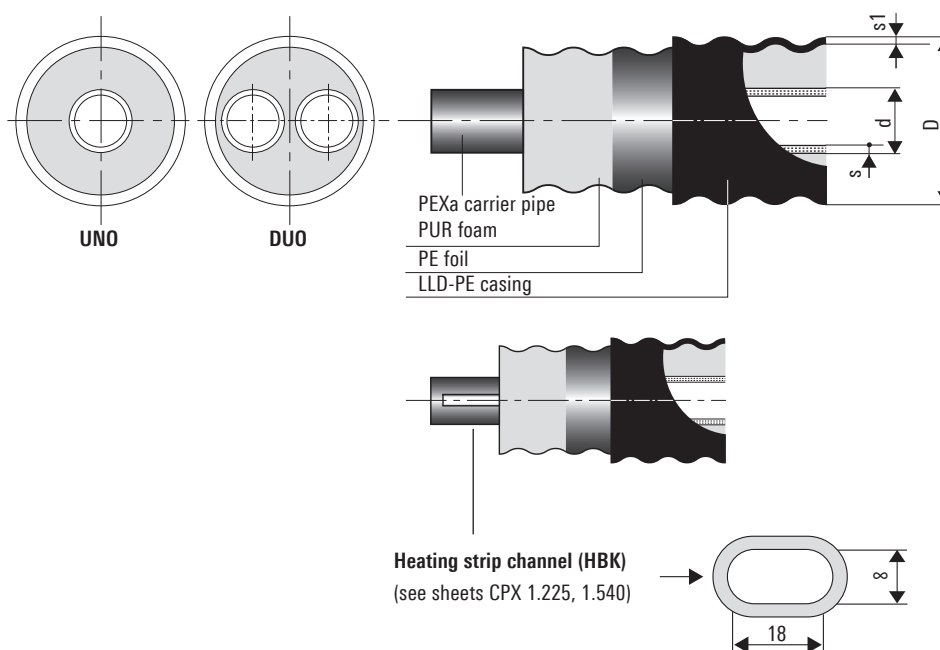

CALPEX SANITARY 10 bar, UNO

Type	Nominal diameter		PEX carrier pipe d x s mm	Outer casing D x s1 mm	Minimum bending radius m	Volume carrier pipe l/m	Weight kg/m	Maximum delivery lengths*	
	DN	Inches						Jumbo coil	Maxi coil
20/ 76	16	5/8	20 x 2.8	78 x 2.0	0.45	0.201	0.96	700	1000
25/ 76	20	3/4	25 x 3.5	78 x 2.0	0.50	0.314	1.06	700	1000
32/ 76	25	1	32 x 4.4	78 x 2.0	0.50	0.423	1.25	700	1000
40/ 91	32	1 1/4	40 x 5.5	93 x 2.2	0.55	0.660	1.77	450	715
50/111	40	1 1/2	50 x 6.9	113 x 2.4	0.60	1.029	2.50	300	450
63/126	50	2	63 x 8.7	128 x 2.7	0.65	1.633	3.40	192	291
32/111 HBK	25	1	32 x 4.4	113 x 2.4	0.60	0.423	1.83	300	450
40/126 HBK	32	1 1/4	40 x 5.5	128 x 2.7	1.00	0.660	2.49	192	291
50/126 HBK	40	1 1/2	50 x 6.9	128 x 2.7	1.00	1.029	2.76	192	291

CALPEX SANITARY 10 bar, DUO

Type	Nominal diameter		PEX carrier pipe d x s mm	Outer casing D x s1 mm	Minimum bending radius m	Volume carrier pipe l/m	Weight kg/m	Maximum delivery lengths*	
	DN	Inches						Jumbo coil	Maxi coil
25 + 20/91	20 + 16	3/4 + 5/8	25 x 3.5 + 20 x 2.8	93 x 2.2	0.55	0.314 + 0.201	1.47	450	715
32 + 20/111	25 + 16	1 + 5/8	32 x 4.4 + 20 x 2.8	113 x 2.4	0.60	0.423 + 0.201	1.95	300	450
40 + 25/126	32 + 20	1 1/4 + 3/4	40 x 5.5 + 25 x 3.5	128 x 2.7	0.65	0.660 + 0.314	2.60	192	291
50 + 32/126	40 + 25	1 1/2 + 1	50 x 6.9 + 32 x 4.4	128 x 2.7	0.65	1.029 + 0.423	1.77	192	291

* Supply as section length, as coils and on drums possible. The delivered coil length may vary (+/- 5%)

- We will produce larger dimensions on request (Ø 75, 90, 110, 125 mm)
- Larger or smaller delivery lengths can be supplied on drums if requested.
- Coil dimensions: **Jumbo coil** outer diameter 2800 mm x 800 mm (width)
Maxi coil outer diameter 2800 mm x 1200 mm (width)

When ordering at the construction site, please observe the total weight of the coil (unwinding equipment)

CALPEX QUADRIGA range

CALPEX QUADRIGA (Heating 6 bar, sanitary 10 bar)

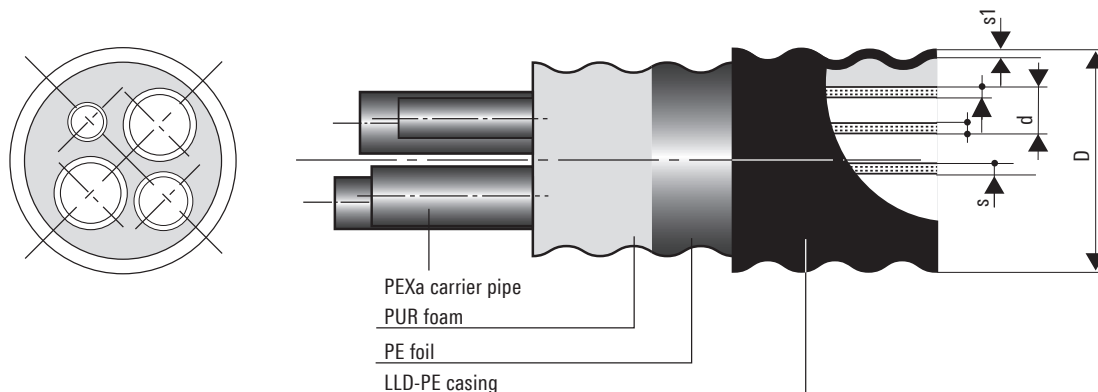

CALPEX, heating 6 bar, sanitary 10 bar, QUADRIGA

Type	Nominal diameter		Carrier pipe d x s mm	Outer casing D x s1 mm	Minimum bending radius m	Volume carrier pipe l/m	Weight kg/m	Maximum delivery length*	
	DN	Inches "						Jumbo coil m	Maxi coil m
H25 + 25/S25 + 20/142	20	¾	25 x 2.3	143 x 3.0	0.7	0.327	3.25	110	180
	20	¾	25 x 2.3						
	20	¾	25 x 3.5						
	16	⅝	20 x 2.8						
H32 + 32/S25 + 20/142	25	1	32 x 2.9	143 x 3.0	0.7	0.539	3.39	110	180
	25	1	32 x 2.9						
	20	¾	25 x 3.5						
	16	⅝	20 x 2.8						
H32 + 32/S32 + 20/142	25	1	32 x 2.9	143 x 3.0	0.7	0.539	3.41	110	180
	25	1	32 x 2.9						
	25	1	32 x 4.4						
	16	⅝	20 x 2.8						
H40 + 40/S40 + 25/162	32	1¼	40 x 3.7	163 x 3.2	1.1	0.835	4.15	65	105
	32	1¼	40 x 3.7						
	32	1¼	40 x 5.5						
	20	¾	25 x 3.5						

* Supply as section length, as coils and on drums possible. The delivered coil length may vary (+/- 5%)

- We will produce different dimensions or special items on request.
- Larger or smaller delivery lengths can be supplied on drums if requested.
- Coil dimensions: **Jumbo coil** outer diameter 2800 mm x 800 mm (width)
Maxi coil outer diameter 2800 mm x 1200 mm (width)

When ordering at the construction site, please observe the total weight of the coil (unwinding equipment)

Pressure loss chart

CALPEX PUR-KING (Heating, 6 bar)

Water temperature 80 °C

Surface roughness $\epsilon = 0.007$ mm (PEXa)

(1 mmWS = 9.81 Pa)

$\dot{m} \approx \frac{Q \cdot 860}{\Delta T}$	\dot{m} =	Flow rate in kg/h
	Q =	Power requirement in kW
	ΔT =	Temperature difference VL (flow)/RL (return) in °C

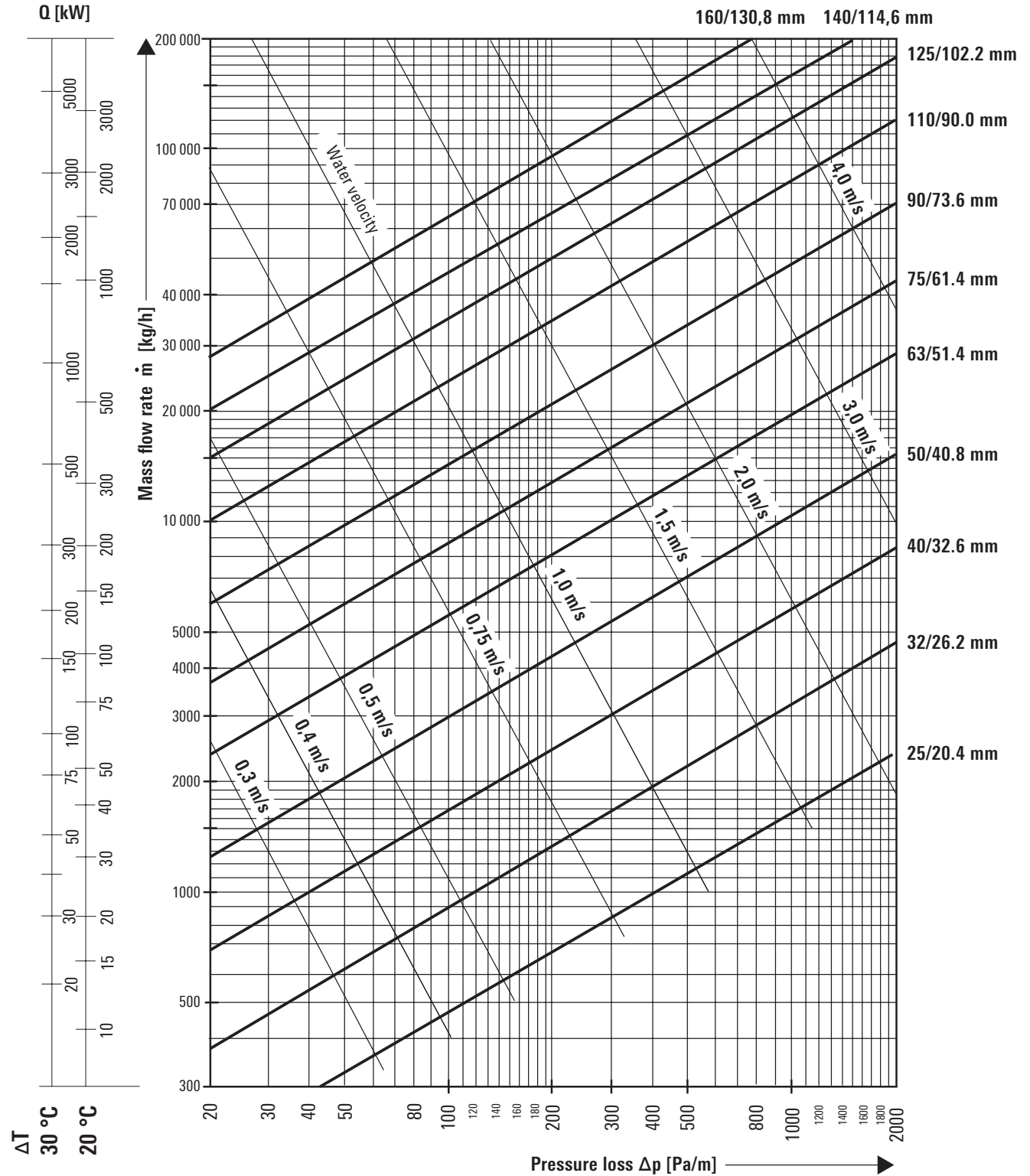

Pressure loss chart

CALPEX SANITARY (Sanitary 10 bar)

Water temperature 60 °C

Surface roughness $\epsilon = 0.007$ mm (PEXa)

(1 mmWS = 9.81 Pa)

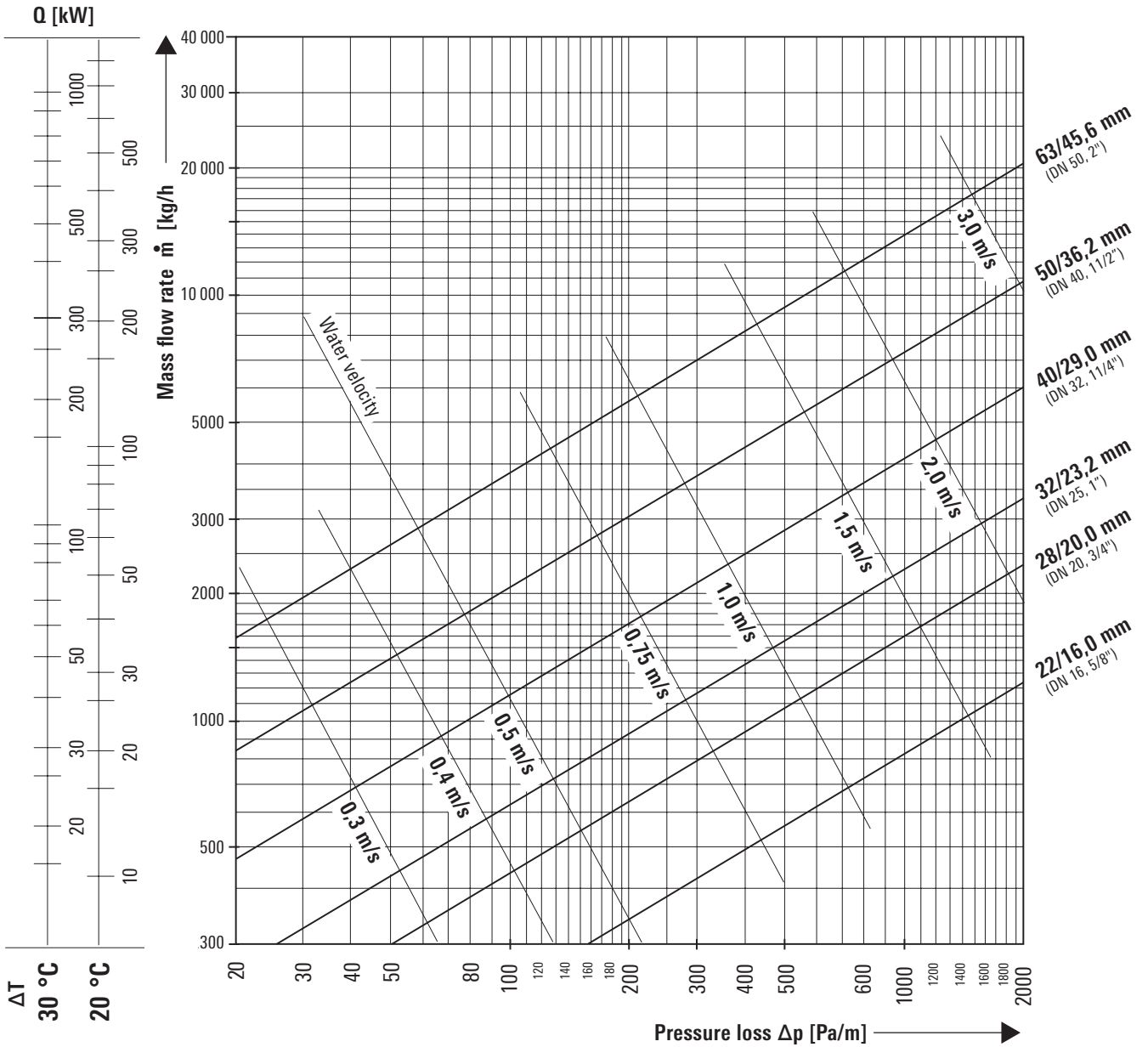

Heat loss

CALPEX PUR-KING (Heating 6 bar)

CALPEX PUR-KING UNO

Heat losses q [W/m] for one UNO pipe						
Type	U-value [W/mK]	Average operating temperature T_B [°C]				
		40°	50°	60°	70°	80°
25/ 76	0.1050	3.15	4.20	5.25	6.30	7.35
25/ 91 PLUS	0.0910	2.73	3.64	4.55	5.46	6.37
32/ 76	0.1320	3.96	5.28	6.60	7.92	9.24
32/ 91 PLUS	0.1110	3.33	4.44	5.55	6.66	7.77
40/ 91	0.1380	4.14	5.52	6.90	8.28	9.66
40/111 PLUS	0.1140	3.42	4.56	5.70	6.84	7.98
50/111	0.1420	4.26	5.68	7.10	8.52	9.94
50/126 PLUS	0.1260	3.78	5.04	6.30	7.56	8.82
63/126	0.1620	4.86	6.48	8.10	9.72	11.34
63/142 PLUS	0.1420	4.26	5.68	7.10	8.52	9.94
75/142	0.1750	5.25	7.00	8.75	10.50	12.25
75/162 PLUS	0.1490	4.47	5.96	7.45	8.94	10.43
90/162	0.1903	5.71	7.61	9.52	11.42	13.32
90/182 PLUS	0.1615	4.85	6.46	8.08	9.69	11.31
110/162	0.2740	8.22	10.96	13.70	16.44	19.18
110/182	0.2181	6.54	8.72	10.91	13.09	15.27
110/202 PLUS	0.1856	5.57	7.42	9.28	11.14	12.99
125/182	0.2807	8.42	11.23	14.04	16.84	19.65
125/202 PLUS	0.2290	6.87	9.16	11.45	13.74	16.03
140/202	0.2891	8.67	11.56	14.46	17.35	20.24
160/250*	0.3028	9.08	12.11	15.14	18.17	21.20

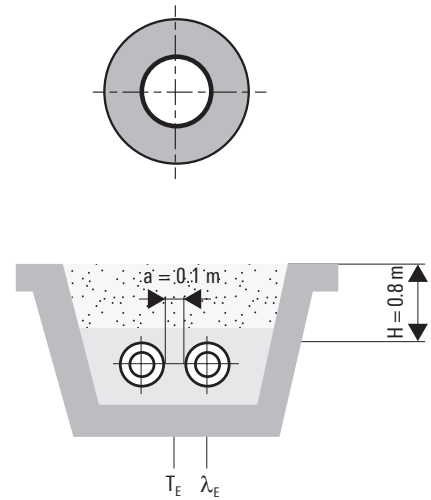

CALPEX PUR-KING DUO

(flow and return in one pipe)

Heat losses q [W/m] for one DUO pipe						
Type	U-value [W/mK]	Average operating temperature T_B [°C]				
		40°	50°	60°	70°	80°
25 + 25/ 91	0.1635	4.91	6.54	8.18	9.81	11.45
25 + 25/111 PLUS	0.1285	3.86	5.14	6.43	7.71	9.00
32 + 32/111	0.1690	5.07	6.76	8.45	10.14	11.83
32 + 32/126 PLUS	0.1431	4.29	5.72	7.16	8.59	10.02
40 + 40/126	0.1909	5.73	7.64	9.55	11.45	13.36
40 + 40/142 PLUS	0.1594	4.78	6.38	7.97	9.56	11.16
50 + 50/162	0.1780	5.34	7.12	8.90	10.68	12.46
50 + 50/182 PLUS	0.1510	4.53	6.04	7.55	9.06	10.57
63 + 63/182	0.2130	6.39	8.52	10.65	12.78	14.91
63 + 63/202 PLUS	0.1780	5.34	7.12	8.90	10.68	12.46
75+75/202	0.2430	7.29	9.72	12.15	14.58	17.01

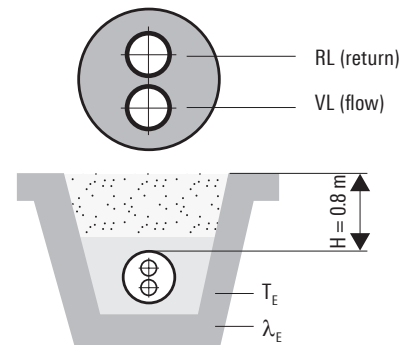

- Type of installation, CPX UNO: 2-pipe, laid in the ground
- Type of installation, CPX DUO: 1-pipe, laid in the ground
- Pipe distance: $a = 0.10 \text{ m}$
- Cover above pipe: $H = 0.80 \text{ m}$
- Ground temperature: $T_E = 10 \text{ °C}$
- Soil conductivity: $\lambda_E = 1.0 \text{ W/mK}$
- Conductivity of PUR-KING foam: $\lambda_{PU} = 0.0199 \text{ W/mK}$
- * Conductivity of PUR foam: $\lambda_{PU} = 0.0260 \text{ W/mK}$
- Conductivity of PEX pipe: $\lambda_{PEXa} = 0.38 \text{ W/mK}$
- Conductivity of PE pipe: $\lambda_{PE} = 0.33 \text{ W/mK}$

Heat loss during operation:

- $q = U (T_B - T_E) \text{ [W/m]}$
- $U = \text{Heat transfer coefficient [W/mK]}$
- $T_B = \text{Average operating temperature [°C]}$
- $T_E = \text{Average ground temperature [°C]}$
- VL = Flow
- RL = Return

Heat loss

CALPEX SANITARY (Sanitary 10 bar)

CALPEX SANITARY UNO

Heat losses q [W/m] for one UNO pipe						
Type	U-value [W/mK]	Average operating temperature T_B [°C]				
		40°	50°	60°	70°	80°
20/ 76	0.1009	3.03	4.04	5.05	6.05	7.06
25/ 76	0.1192	3.58	4.77	5.96	7.15	8.34
32/ 76	0.1588	4.76	6.35	7.94	9.53	11.12
40/ 91	0.1666	5.00	6.66	8.33	10.00	11.66
50/111	0.1713	5.14	6.85	8.57	10.28	11.99
63/126	0.1957	5.87	7.83	9.79	11.74	13.70
32/111 HBK	0.1127	3.38	4.51	5.64	6.76	7.89
40/126 HBK	0.1220	3.66	4.88	6.10	7.32	8.54
50/126 HBK	0.1497	4.49	5.99	7.49	8.98	10.48

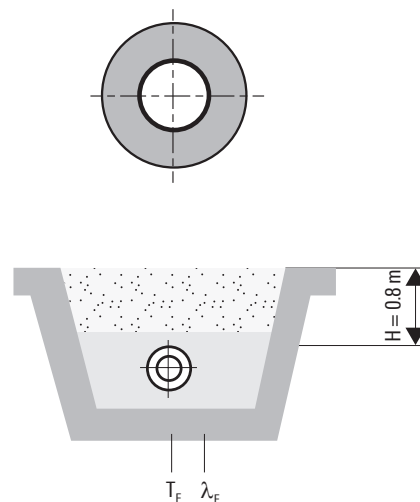

CALPEX SANITARY DUO

Heat losses q [W/m] for one DUO pipe						
Type	U-value [W/mK]	Average operating temperature T_B [°C]				
		40°	50°	60°	70°	80°
25 + 20/ 91	0.1710	5.13	6.84	8.55	10.26	11.97
32 + 20/111	0.1630	4.89	6.52	8.15	9.78	11.41
40 + 25/126	0.1780	5.34	7.12	8.90	10.68	12.46
50 + 32/126	0.2476	7.43	9.90	12.38	14.86	17.33

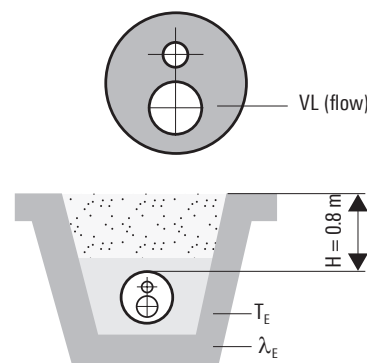

Type of installation, CPX UNO: 1-pipe, laid in the ground
 Type of installation, CPX DUO: 1-pipe, laid in the ground
 Cover above pipe: $H = 0.80$ m
 Ground temperature: $T_E = 10$ °C
 Soil conductivity: $\lambda_E = 1.0$ W/mK
 Conductivity of PUR foam: $\lambda_{PU} = 0.0234$ W/mK
 Conductivity of PEX pipe: $\lambda_{PEXa} = 0.38$ W/mK
 Conductivity of PE pipe: $\lambda_{PE} = 0.33$ W/mK

Heat loss during operation:

$q = U (T_B - T_E)$ [W/m]
 U = Heat transfer coefficient [W/mK]
 T_B = Average operating temperature [°C]
 T_E = Average ground temperature [°C]

Heat loss

CALPEX QUADRIGA (Heating 6 bar, Sanitary 10 bar)

CALPEX QUADRIGA

Heat losses q [W/m] for one QUADRIGA pipe					
Type	U-value [W/mK]	Average operating temperature T _B [°C]			
		50°	55°	60°	65°
H 25 + 25/S 25 + 20/142	0.1542	6.17	6.94	7.71	8.48
H 32 + 32/S 25 + 20/142	0.1785	7.14	8.03	8.93	9.82
H 32 + 32/S 32 + 20/142	0.1930	7.72	8.69	9.65	10.62
H 40 + 40/S 40 + 25/162	0.2279	9.12	10.26	11.40	12.53

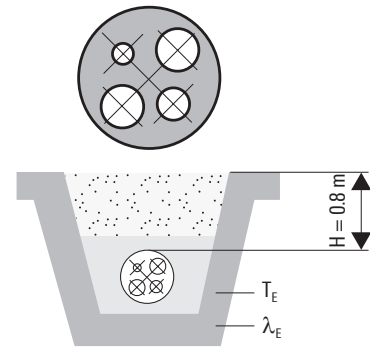

Type of installation for QUADRIGA: 1-pipe, laid in the ground

- Cover above pipe: H = 0.80 m
- Ground temperature: T_E = 10 °C
- Soil conductivity: λ_E = 1.0 W/mK
- Conductivity of PUR foam: λ_{PU} = 0.0234 W/mK
- Conductivity of PEXa pipe: λ_{PEX} = 0.38 W/mK
- Conductivity of PE pipe: λ_{PE} = 0.33 W/mK

Heat loss during operation:

- q = U (T_B - T_E) [W/m]**
- U = Heat transfer coefficient [W/mK]
- T_B = Average operating temperature [°C]
- T_E = Average ground temperature [°C]

CALPEX QUADRIGA - heat loss during operation

Example of calculation for average operating temperature T_B [°C]

- Flow - heating: 70 °C
- Return - heating: 40 °C
- Flow - sanitary: 60 °C
- Return - sanitary: 50 °C

$$T_B = \frac{70^\circ + 40^\circ + 60^\circ + 50^\circ}{4} = 55^\circ\text{C}$$

Planning and connection technology

CALPEX SANITARY (Heating strip)

1. Requirements for heating strip

1.1 Minimum power

Type CALPEX UNO	In relation to a maintained temperature of:		
	40 °C	50 °C	60 °C
32/111	5.8 W/m	7.8 W/m	9.6 W/m
40/126	6.3 W/m	8.3 W/m	10.4 W/m
50/126	7.3 W/m	10.3 W/m	12.8 W/m

1.2 Recommendations for heating strip

Hot water:

HWAT-R from Tyco Thermal Controls N.V. meets the requirement for Ø 50/126, 60 °C
Automatic power adjustment with HWAT-ECO

Frost protection:

FS-B-2X from Tyco Thermal Controls N.V. requires thermostat with temperature sensor, UTR15

Max. heating circuit length in relation to a cut-in temperature of 12 °C (HWAT) or 0 °C (FS-B-2X)		
Heating strip type	Fuse	Length Lmax
HWAT-R	13 A	60 m
	16 A	80 m
	20 A	100 m
FS-B-2X	10 A	65 m
	16 A	105 m

Fuse protection using automatic cutouts with characteristic C

2. Joint

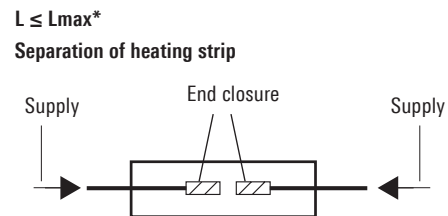
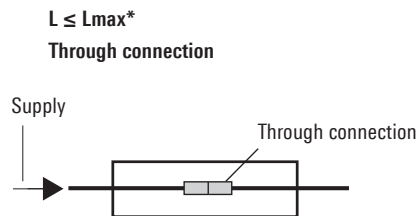

3. T-branch

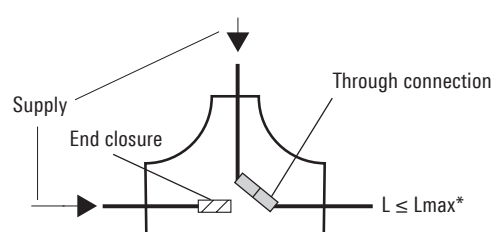
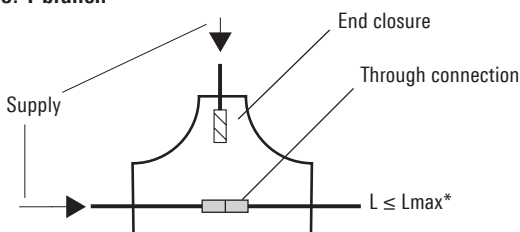

For the T-branch, note that the sum of two connected pipes must not be $> L_{max}^*$. T-switches **cannot** be supplied.

* L_{max} = max. permitted length for heating strip

The heating strip and the accessories are installed by the electrician!

House entry bend, 90°

CALPEX PUR-KING UNO (Heating 6 bar)

Bend, 90° delivered without press fittings

Dimensions: CPX 25/76 - 125/182*

CPX 160/250**

Bend, 90° DN 150 (St 37.0) with welded-on press fittings

Dimensions: CPX 140/202 - Carrier pipe P235

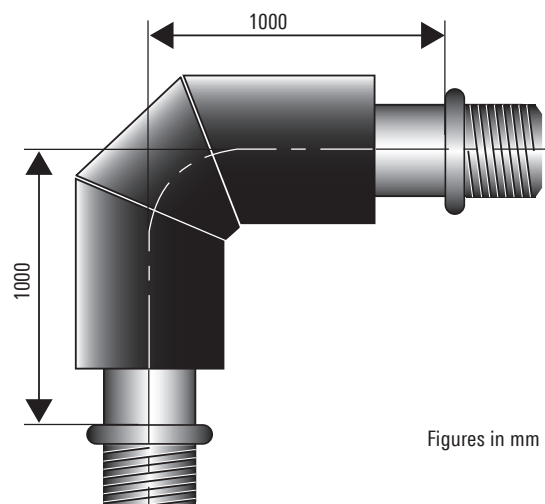
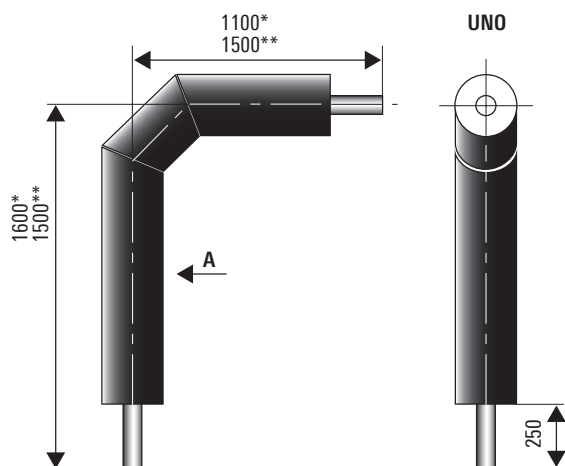

Figures in mm

CALPEX PUR-KING UNO

Type	PEX carrier pipe d x s mm	Outer casing D x s1 mm	Volume carrier pipe l/m	Weight kg/unit
25/ 76	25 x 2.3	75 x 2.9	0.32	2.30
25/ 91 PLUS	25 x 2.3	90 x 3.5	0.32	-
32/ 76	32 x 2.9	75 x 2.9	0.53	2.50
32/ 91 PLUS	32 x 2.9	90 x 3.5	0.53	-
40/ 91	40 x 3.7	90 x 3.5	0.83	3.47
40/111 PLUS	40 x 3.7	110 x 4.3	0.83	-
50/111	50 x 4.6	110 x 4.3	1.30	4.92
50/126 PLUS	50 x 4.6	125 x 4.9	1.30	-
63/126	63 x 5.8	125 x 4.9	2.07	6.50
63/142 PLUS	63 x 5.8	140 x 4.4	2.07	-
75/142	75 x 6.8	140 x 4.4	2.96	8.47
75/162 PLUS	75 x 6.8	160 x 5.0	2.96	-
90/162	90 x 8.2	160 x 5.0	4.25	11.40
90/182 PLUS	90 x 8.2	180 x 5.6	4.25	-
110/162	110 x 10.0	160 x 5.0	6.36	14.23
110/182	110 x 10.0	180 x 5.6	6.36	16.19
110/202 PLUS	110 x 10.0	200 x 6.2	6.36	-
125/182	125 x 11.4	180 x 5.6	8.20	17.20
125/202 PLUS	125 x 11.4	200 x 6.2	8.20	-
140/225	140 x 12.7	225 x 6.9	13.79	40.95
160/250	160 x 14.6	250 x 6.2	20.18	58.40

Connection with press connections (for coupling, see CPX 1.390)

Supplementary insulation ≤ Ø 182 mm with CPX clip shells (for CPX-I shell, see CPX 1.325/1.326) or ≥ Ø 202 mm with shrink-on sleeves (see CPX 1.320)

House entry bend 90°

CALPEX PUR-KING DUO (Heating 6 bar)

Bend 90° delivered without press fittings

Dimensions: CPX 25/25/91 - 75+75/202

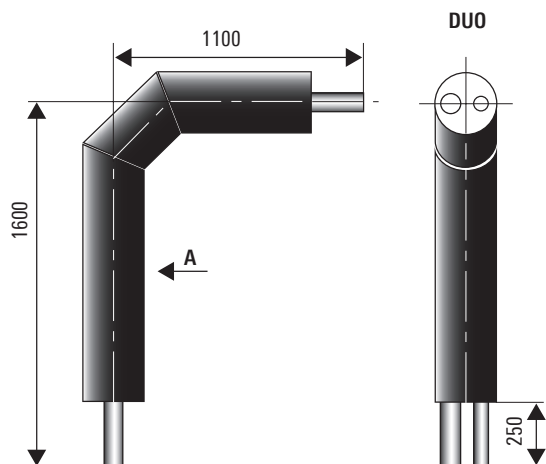

Figures in mm

CALPEX PUR-KING DUO

Type	PEX carrier pipe d x s mm	Outer casing D x s1 mm	Volume carrier pipe l/m	Weight kg/unit
25 + 25/ 91	2 x 25 x 2.3	90 x 3.5	2 x 0.32	4.32
25 + 25/111 PLUS	2 x 25 x 2.3	110 x 4.3	2 x 0.32	-
32 + 32/111	2 x 32 x 2.9	110 x 4.3	2 x 0.53	4.67
32 + 32/126 PLUS	2 x 32 x 2.9	125 x 4.9	2 x 0.53	-
40 + 40/126	2 x 40 x 3.7	125 x 4.9	2 x 0.83	7.42
40 + 40/142 PLUS	2 x 40 x 3.7	140 x 4.3	2 x 0.83	-
50 + 50/162	2 x 50 x 4.6	160 x 5.0	2 x 1.30	9.90
50 + 50/182 PLUS	2 x 50 x 4.6	180 x 5.6	2 x 1.30	-
63 + 63/182	2 x 63 x 5.8	180 x 5.6	2 x 2.07	13.96
63 + 63/202 PLUS	2 x 63 x 5.8	200 x 6.2	2 x 2.07	-
75 + 75/202	2 x 75 x 6.8	200 x 6.2	2 x 2.96	-

Connection with press connections (for coupling, see CPX 1.390)

Supplementary insulation ≤ Ø 182 mm with CPX clip shells (for CPX-I shell, see CPX 1.325/1.326) or ≥ Ø 202 mm with shrink-on sleeves (see CPX 1.320)

House entry bend, 90°

CALPEX SANITARY UNO/DUO (Sanitary 10 bar)

Bend, 90° delivered without press fittings

Dimensions: CPX 20/76 - 63/126

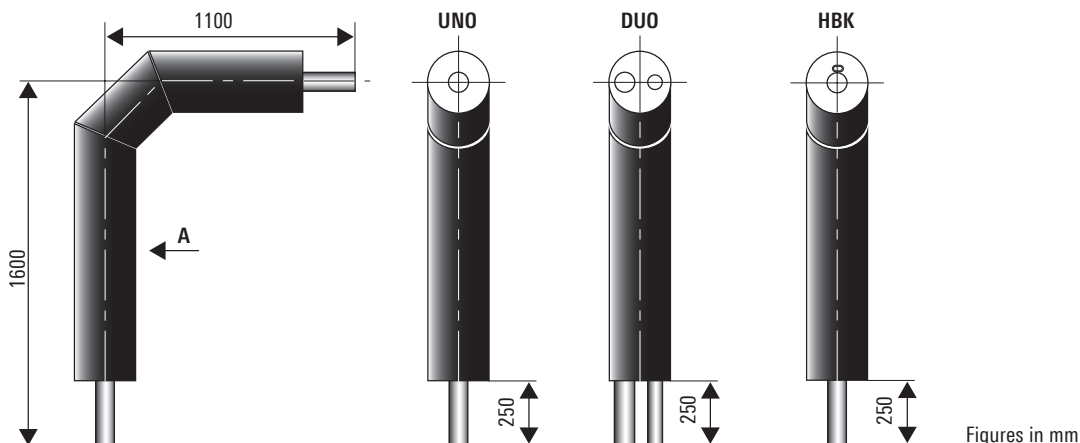

Figures in mm

CALPEX SANITARY UNO

Type	DN	Inches	PEX carrier pipe d x s mm	Outer casing D x s1 mm	Volume carrier pipe l/m	Weight kg/unit
20/ 76	16	5/8	20 x 2.8	75 x 2.9	0.20	2.40
25/ 76	20	3/4	25 x 3.5	75 x 2.9	0.31	2.65
32/ 76	25	1	32 x 4.4	75 x 2.9	0.42	2.80
40/ 91	32	1 1/4	40 x 5.5	90 x 3.5	0.66	3.90
50/111	40	1 1/2	50 x 6.9	110 x 4.3	1.02	5.62
63/126	50	2	63 x 8.7	125 x 4.9	1.63	7.65
32/111 HBK	25	1	32 x 4.4	110 x 4.3	0.42	6.53
40/126 HBK	32	1 1/4	40 x 5.5	125 x 4.9	0.66	8.56
50/126 HBK	40	1 1/2	50 x 6.9	125 x 4.9	1.02	9.38

CALPEX SANITARY DUO

Type	DN	Inches	PEX carrier pipe d x s mm	Outer casing D x s1 mm	Volume carrier pipe l/m	Weight kg/unit
25 + 20/ 91	20 + 16	3/4 + 5/8	25.0 x 3.5 + 20.0 x 2.8	90 x 3.5	0.31 + 0.20	3.67
32 + 20/111	25 + 16	1 + 5/8	32.0 x 4.4 + 20.0 x 2.8	110 x 4.3	0.42 + 0.20	4.87
40 + 25/126	32 + 20	1 1/4 + 3/4	40.0 x 5.5 + 25.0 x 3.5	125 x 4.9	0.66 + 0.31	6.50
50 + 32/126	40 + 25	1 1/2 + 1	50.0 x 6.9 + 32.0 x 4.4	125 x 4.9	1.02 + 0.42	7.30

Connection with press connections (for coupling, see CPX 1.390)

Supplementary insulation with CPX clip shells (for CPX-I shell, see CPX 1.325/1.326) or with shrink-on sleeves (see CPX 1.320)

House entry bend, 90°

CALPEX QUADRIGA (Heating 6 bar, Sanitary 10 bar)

Bend, 90° DN 16 - DN 32

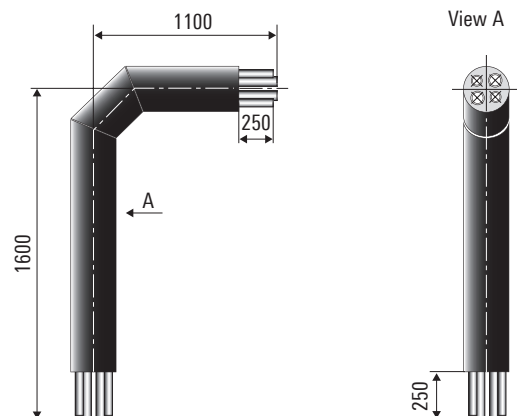

Figures in mm

CALPEX QUADRIGA

Type	DN	Inches	PEX carrier pipe d x s mm	Outer casing D x s1 mm	Volume carrier pipe l/m	Weight kg/unit
H25+25/S25+20/142	20	¾	25 x 2.3	140 x 4.4	0.327	8.12
	20	¾	25 x 2.3		0.327	
	20	¾	25 x 3.5		0.314	
	16	⅝	20 x 2.8		0.201	
H32+32/S25+20/142	25	1	32 x 2.9	140 x 4.4	0.539	8.47
	25	1	32 x 2.9		0.539	
	20	¾	25 x 4.0		0.314	
	16	⅝	20 x 2.8		0.201	
H32+32/S32+20/142	25	1	32 x 2.9	140 x 4.4	0.539	8.52
	25	1	32 x 2.9		0.539	
	25	1	32 x 4.4		0.423	
	16	⅝	20 x 2.8		0.201	
H40+40/S40+25/162	32	1¼	40 x 3.7	160 x 5.0	0.835	10.37
	32	1¼	40 x 3.7		0.835	
	32	1¼	40 x 5.5		0.660	
	20	¾	25 x 3.5		0.314	

Connection with press connections (for coupling, see CPX 1.390)

Supplementary insulation with shrink-on sleeves (see CPX 1.320)

CALPEX L-shell

Dimensions Ø 76 - 126 mm

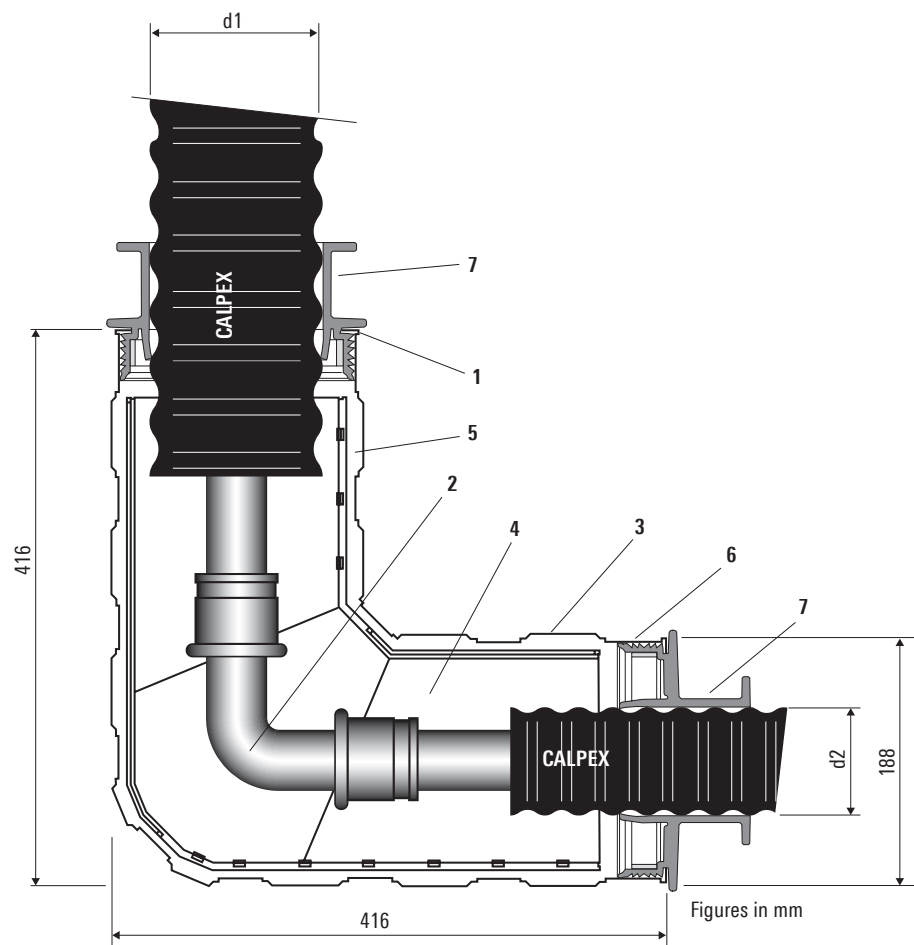

CALPEX L-shell, UNO/DUO

Outer casing Ø d1	Ø d2			
	76	91	111	126
76	x			
91		x		
111			x	
126				x

Note: CALPEX shells are not suggested to be installed UV exposed!

CALPEX shells are not suitable for use with CALPEX QUADRIGA (distribution chamber: see CPX 1.350).

Structure of the half-shell

- 1 ABS half-shells
- 2 PEX angle coupling; see CPX 1.390
- 3 Sealing clamps (15 pcs.)
- 4 Insulation material; see CPX 1.365
- 5 Glued surface
- 6 Reduction ring or sealing ring
- 7 Hose clip

CALPEX Big L-shell

Dimensions Ø 142 - 182 mm

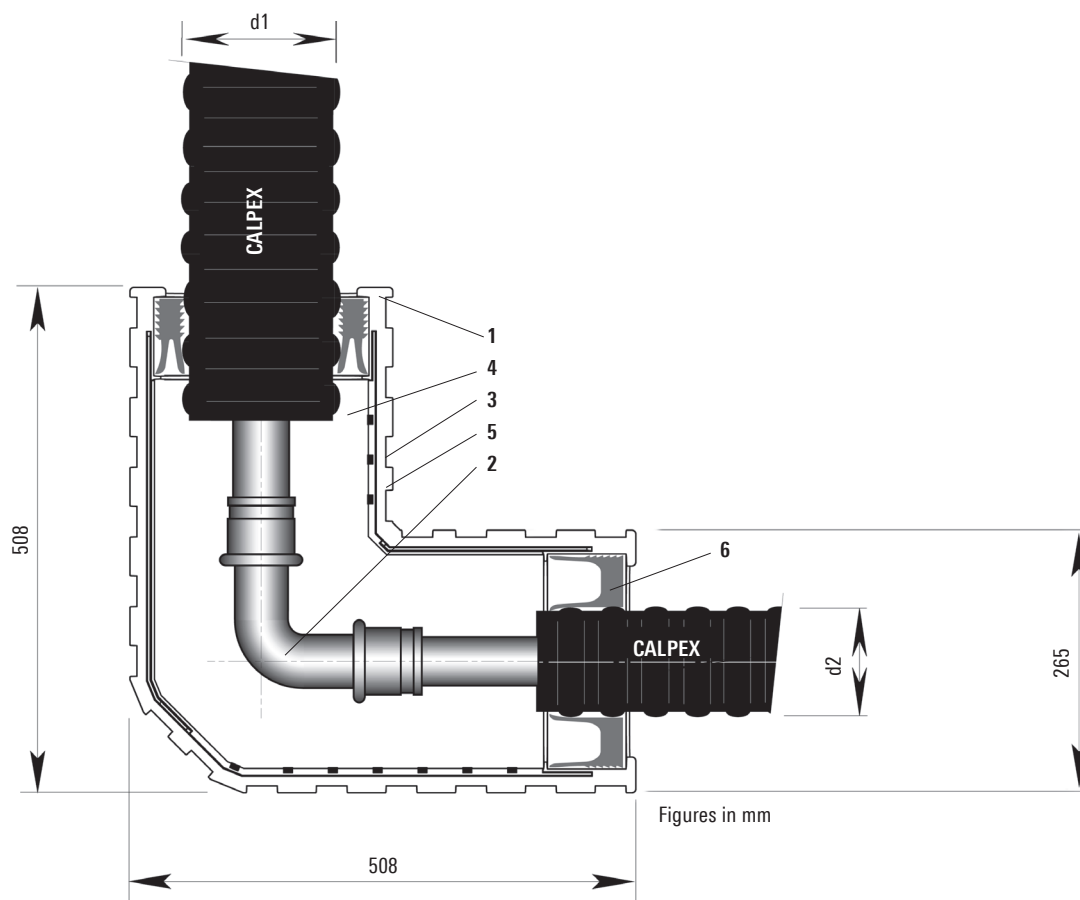

CALPEX Big L-shell, UNO/DUO

Outer casing Ø d1	Ø d2		
	142	162	182
142	x		
162		x	
182			x

Note: CALPEX shells are not suggested to be installed UV exposed!

CALPEX shells are not suitable for use with CALPEX QUADRIGA (distribution chamber: see CPX 1.350).

CALPEX Big-shells are freely reducible from Ø 182 mm to Ø 76 mm

Structure of the half-shell

- 1 ABS half-shells
- 2 PEX angle coupling; see CPX 1.390
- 3 Sealing clamps (22 pcs.)
- 4 Insulation material; see CPX 1.365
- 5 Glued surface
- 6 Reduction ring or sealing ring

Joint using PE-HD shrink sleeve

Dimensions Ø 76 - 250 mm

CALPEX joint

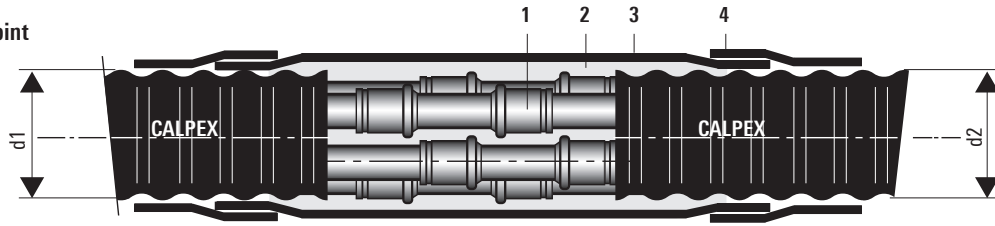

CALPEX reduction joint

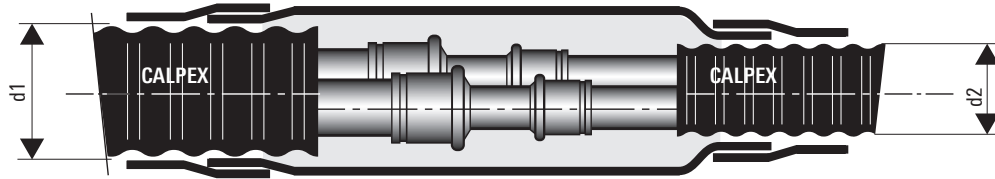

CALPEX – Insulated steel pipe

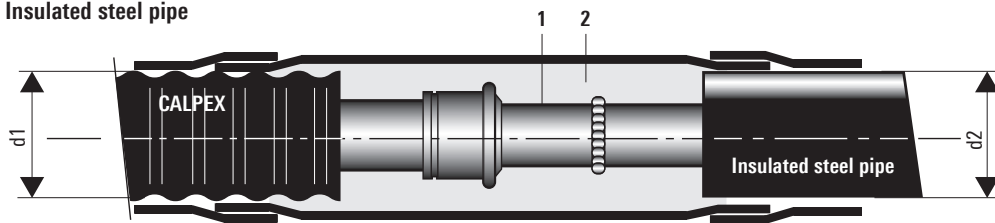

- 1 PEX coupling; see sheet 1.390
- 2 Insulation material, PUR or PE; see sheet 1.365
- 3 Shrink sleeve pipe
- 4 Shrink hose

Installation note:

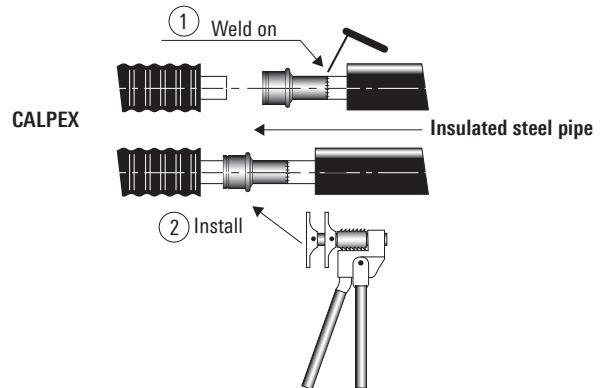

CALPEX-CALPEX

	Ø d2	76	91	111	126	142	162	182	250
Ø d1	76	x	x						
	91		x	x					
	111			x	x				
	126				x	x			
	142					x	x		
	162						x	x	
	182							x	x
	250								x

CALPEX to insulated steel pipe

	Ø d2	90	110	125	140	160	180	200	225	250	280	315
Ø d1	76	x	x	x								
	91	x	x	x	x							
	111	x	x	x	x							
	126		x	x	x	x						
	142			x	x	x	x					
	162				x	x	x	x	x	x		
	182				x	x	x	x	x	x	x	
	250										x	x

CALPEX I-shell

Dimensions Ø 76 - 126 mm

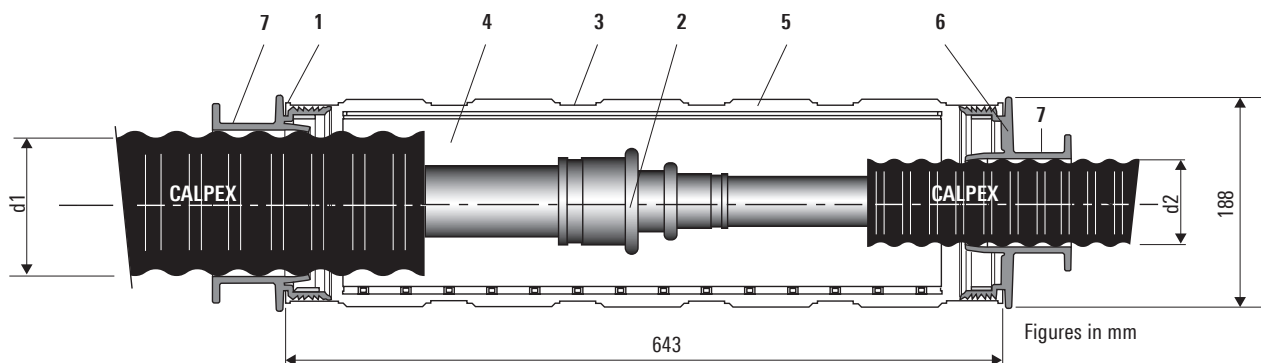

CALPEX I-shell, UNO/DUO

Outer casing Ø d1	Ø d2			
	76	91	111	126
76	x			
91	x	x		
111	x	x	x	
126	x	x	x	x

Note: CALPEX shells are not suggested to be installed UV exposed!

CALPEX shells are not suitable for use with CALPEX QUADRIGA (distribution chamber: see CPX 1.350).

Structure of the half-shell

- 1 ABS half-shells
- 2 PEX coupling; see CPX 1.390
- 3 Sealing clamps (14 pcs.)
- 4 Insulation material; see CPX 1.365
- 5 Glued surface
- 6 Reduction ring or sealing ring
- 7 Hose clip

CALPEX Big I-shell

Dimensions Ø 142 - 182 mm

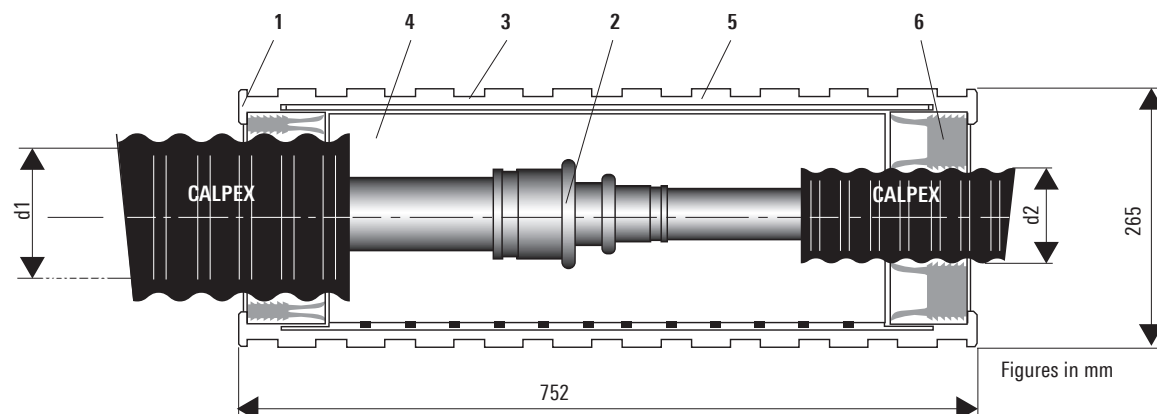

CALPEX Big I-shell, UNO/DUO/QUADRIGA

Outer casing Ø d1	Ø d2		
	142	162	182
142	x		
162	x	x	
182	x	x	x

Note: CALPEX shells are not suggested to be installed UV exposed!

Distribution chamber: see CPX 1.350

CALPEX Big-shells are freely reducible from Ø 182 mm to Ø 76 mm

Structure of the half-shell

- 1 ABS half-shells
- 2 PEX coupling; see CPX 1.390
- 3 Sealing clamps (22 pcs.)
- 4 Insulation material; see CPX 1.365
- 5 Glued surface
- 6 Reduction ring or sealing ring

CALPEX T-shell

Dimensions Ø 76 - 126 mm

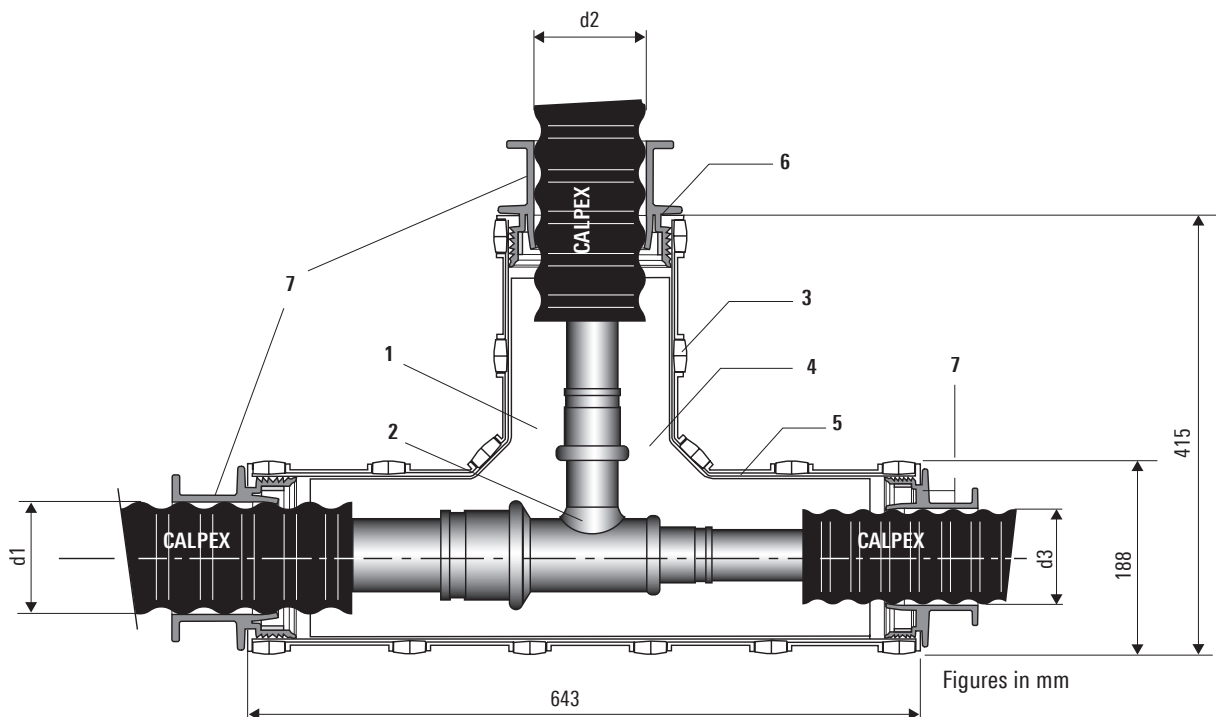

CALPEX T-shell, UNO/DUO

Outer casing Ø d1 - Ø d3	Branch, Ø d2			
	76	91	111	126
76 - 76	x	x	x	x
91 - 91	x	x	x	x
91 - 76	x	x	x	x
111 - 111	x	x	x	x
111 - 91	x	x	x	x
111 - 76	x	x	x	x
126 - 126	x	x	x	x
126 - 111	x	x	x	x
126 - 91	x	x	x	x
126 - 76	x	x	x	x

Structure of the half-shell

- 1 ABS half-shells
- 2 PEX T-piece; see CPX 1.395
- 3 Sealing clamps (20 pcs.)
- 4 Insulation material; see CPX 1.365
- 5 Glued surface
- 6 Reduction ring or sealing ring
- 7 Hose clip

Note: CALPEX shells are not suggested to be installed UV exposed!

CALPEX shells are not suitable for use with CALPEX QUADRIGA (distribution chamber: see CPX 1.350).

CALPEX Big T-shell

Dimensions Ø 76 - 182 mm

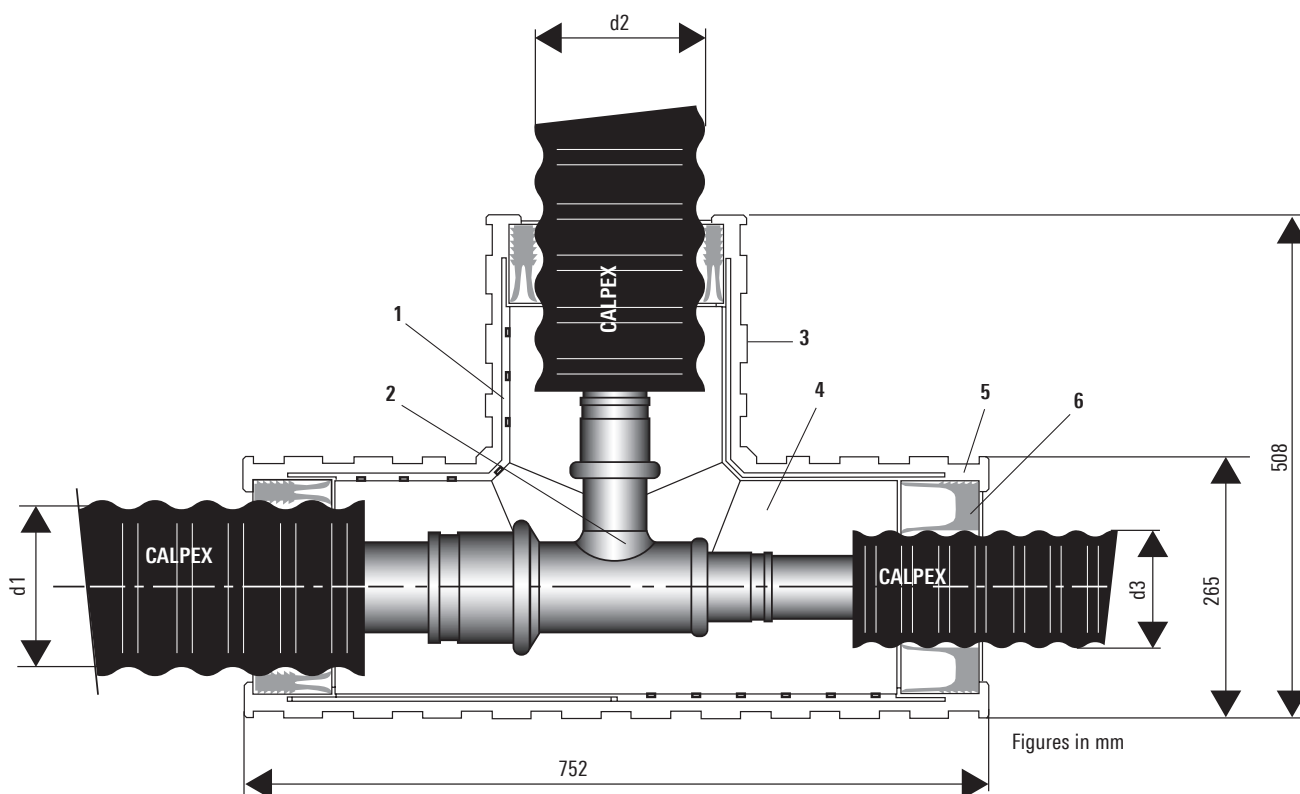

CALPEX Big T-shell, UNO/DUO

Outer casing Ø d1 - Ø d3	Branch, Ø d2						
	76	91	111	126	142	162	182
142 - 142	x	x	x	x	x	x	x
142 - 126	x	x	x	x	x	x	x
142 - 111	x	x	x	x	x	x	x
142 - 91	x	x	x	x	x	x	x
142 - 76	x	x	x	x	x	x	x
162 - 162	x	x	x	x	x	x	x
162 - 142	x	x	x	x	x	x	x
162 - 126	x	x	x	x	x	x	x
162 - 111	x	x	x	x	x	x	x
162 - 91	x	x	x	x	x	x	x
162 - 76	x	x	x	x	x	x	x
182 - 182	x	x	x	x	x	x	x
182 - 162	x	x	x	x	x	x	x
182 - 142	x	x	x	x	x	x	x
182 - 126	x	x	x	x	x	x	x
182 - 111	x	x	x	x	x	x	x
182 - 91	x	x	x	x	x	x	x
182 - 76	x	x	x	x	x	x	x

Structure of the half-shell

- 1 ABS half-shells
- 2 PEX T-piece; see CPX 1.395
- 3 Sealing clamps (27 pcs.)
- 4 Insulation material; see CPX 1.365
- 5 Glued surface
- 6 Reduction ring or sealing ring

Note: CALPEX shells are not suggested to be installed UV exposed!

CALPEX shells are not suitable for use with CALPEX QUADRIGA (distribution chamber: see CPX 1.350).

CALPEX Big-shells are freely reducible from Ø 182 mm to Ø 76 mm

CALPEX-PE-T-Shell

Dimension Ø 202 mm

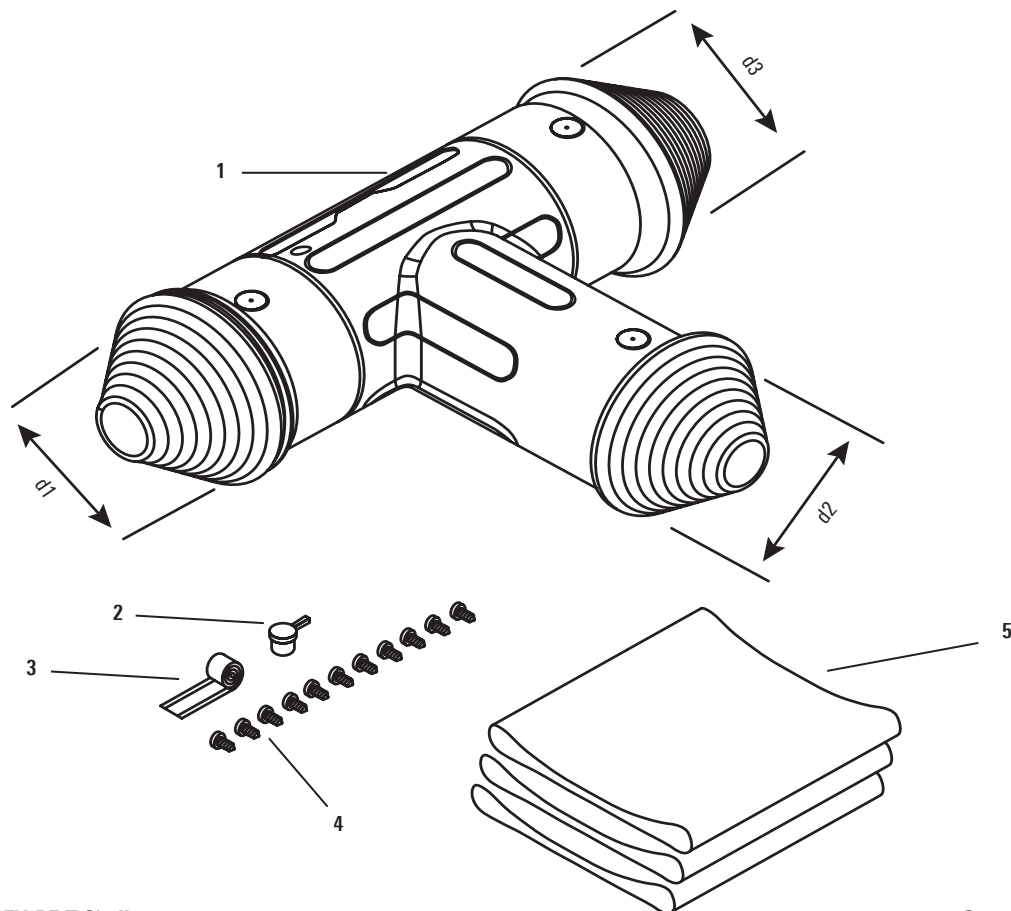

CALPEX-PE-T-Shell

Outer casing Ø d1 - Ø d3	Branch, Ø d2						
	91	111	126	142	162	182	202
202 - 202	x	x	x	x	x	x	x
202 - 182	x	x	x	x	x	x	x
202 - 162	x	x	x	x	x	x	x
202 - 142	x	x	x	x	x	x	x
202 - 126	x	x	x	x	x	x	x
202 - 111	x	x	x	x	x	x	x
202 - 91	x	x	x	x	x	x	x

Structure of the PE-Shell

- 1 PE-T-Shell
- 2 Sealing plug
- 3 Butyl sealing tape
- 4 Sealing screws
- 5 Heat-shrink sleeves

T-joint

CALPEX PUR-KING 125/225 - 160/250

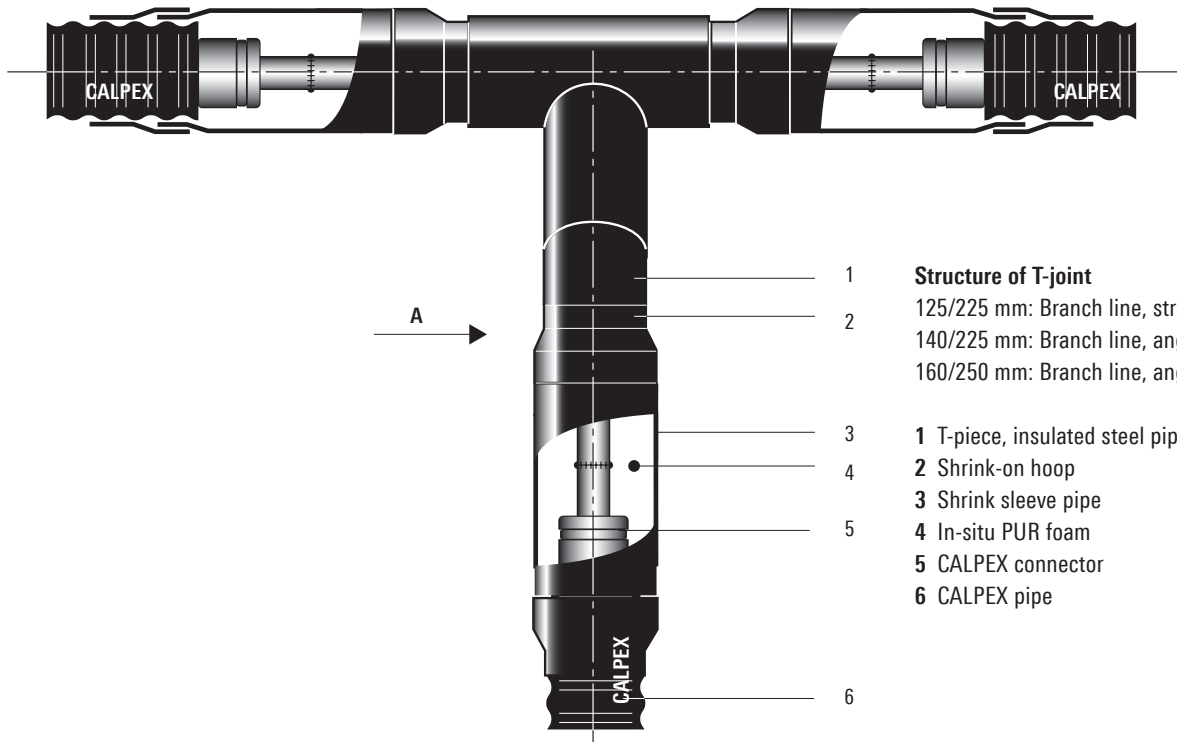

Structure of T-joint

125/225 mm: Branch line, straight
 140/225 mm: Branch line, angled 45°
 160/250 mm: Branch line, angled 45°

- 1 T-piece, insulated steel pipe (St 37.0)
- 2 Shrink-on hoop
- 3 Shrink sleeve pipe
- 4 In-situ PUR foam
- 5 CALPEX connector
- 6 CALPEX pipe

CALPEX UNO (Ø 140, 160 mm)

View A

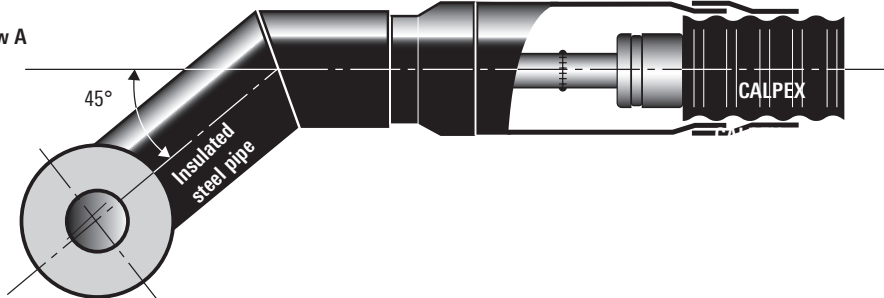

CALPEX UNO (Ø 125 mm) / CALPEX DUO (Ø 75 + 75 mm)

on request

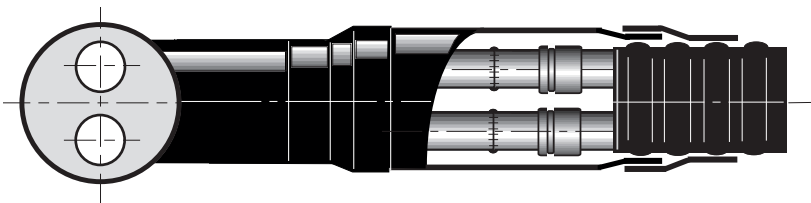

CALPEX T-joint

Outer casing Ø d1 Ø d3	Branch, Ø d2											
	25/76	32/76	40/91	50/111	63/126	75/142	90/162	110/162	110/182	125/182	140/225	160/250
125/225 - 125/225*	x	x	x	x	x	x	x	x	x	x	—	—
140/225 - 140/225*	x	x	x	x	x	x	x	x	x	x	x	—
160/250 - 160/250	x	x	x	x	x	x	x	x	x	x	x	x

* Reduction sockets are required

We can supply T-pieces with different branches on request for CALPEX-UNO and DUO pipes

Y-pipe

CALPEX PUR-KING (Heating, 6 bar)

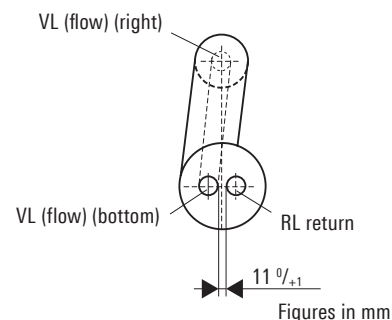
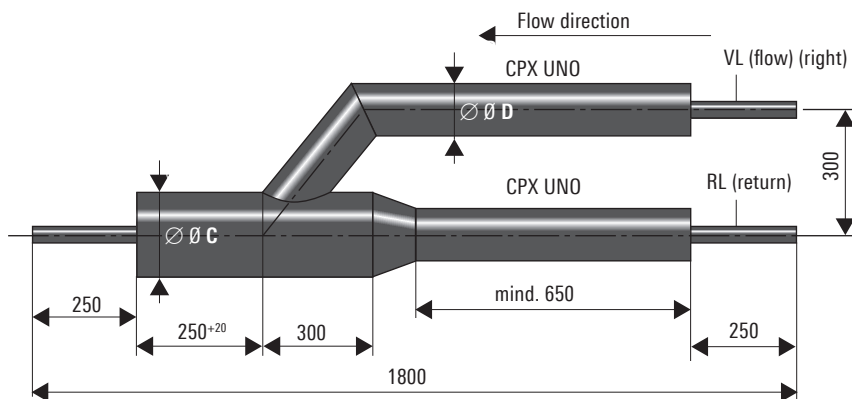

View: A - A

Note: With UNO pipe, in the direction of flow, the forward flow (VL) is always on the right and with DUO pipe, it is always at the bottom.

CALPEX DUO / 2 x CALPEX UNO

UNO pipes mm	Ø D mm	DUO CPX pipe mm	Ø C mm
2 x 25/ 76	75	25 + 25/ 91	90
2 x 25/ 91 PLUS	90	25 + 25/111	110
2 x 32/ 76	75	32 + 32/111	110
2 x 32/ 91 PLUS	90	32 + 32/126	125
2 x 40/ 91	90	40 + 40/126	125
2 x 40/111 PLUS	110	40 + 40/142	140
2 x 50/111	110	50 + 50/162	160
2 x 50/126 PLUS	125	50 + 50/182	180
2 x 63/126	125	63 + 63/182	180
2 x 63/142 PLUS	140	63 + 63/202	200
2 x 75/142	140	75 + 75/202	225*

*Reduction sockets Ø 225/202 are required

PEXa carrier pipe – made of steel on request (P235 TR 1/GH)

Connection with press connections (for coupling, see CPX 1.390)

Supplementary insulation with CPX clip shells (for CPX-I shell, see CPX 1.325/1.326)

or with shrink-on sleeves (see CPX 1.320)

Distribution chamber

Dimensions CPX 25/76 - 125/182

Distribution chamber for all joints

The distribution chamber is used to cover and protect completed BRUGG pipe joints, shut-off valves or junction branches. The distribution chamber is a watertight structure made of polyethylene; its multi-functional design makes it possible to use one chamber type for all pipe dimensions.

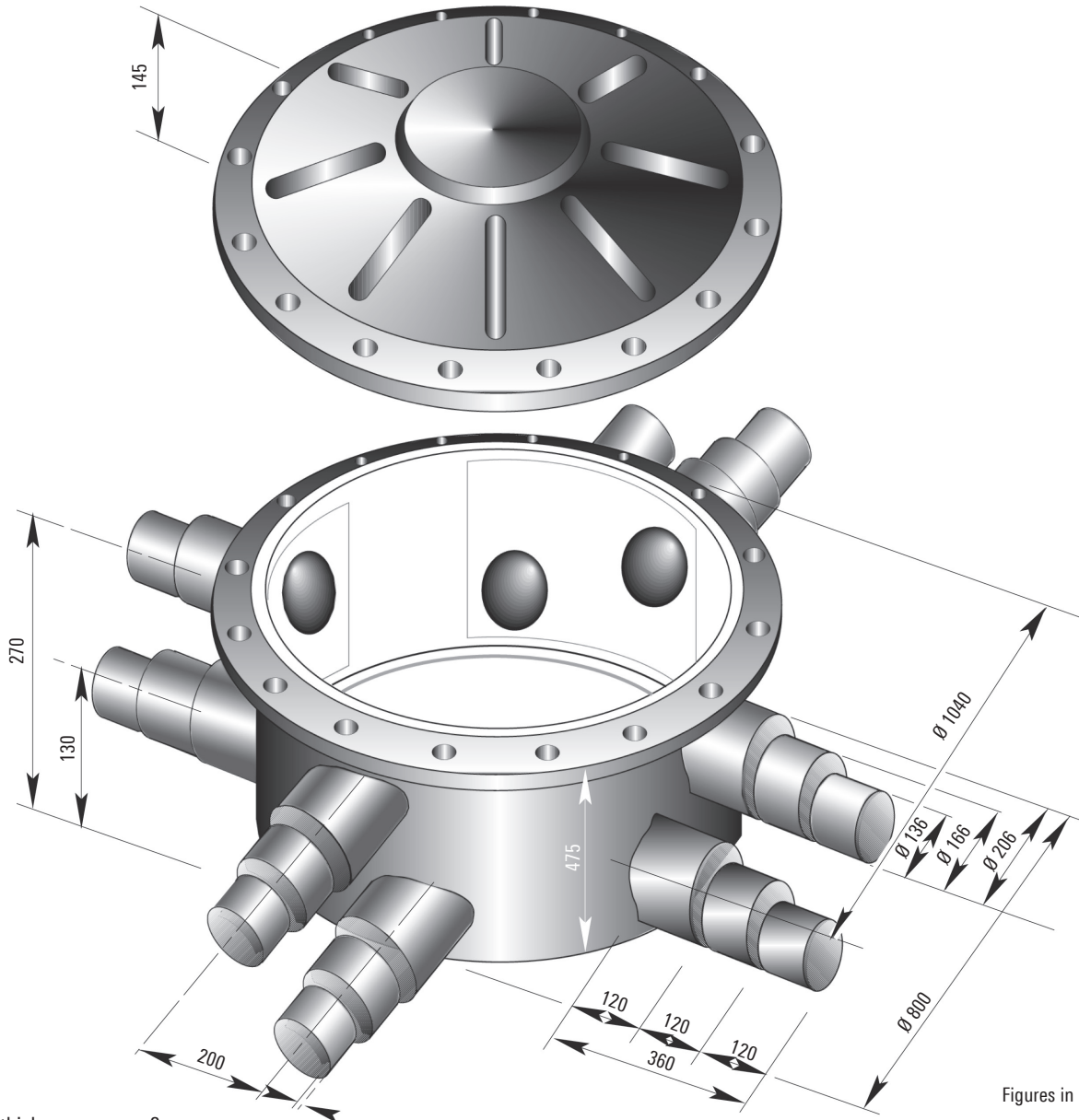

Wall thickness approx. 8 mm

Figures in mm

Ø Chamber exit	Pipe dimensions (outer diameter)	
Ø outer, 206 x 8 mm	Leadthrough for outer Ø	Ø 182, 162*
Ø outer, 166 x 8 mm	Leadthrough for outer Ø	Ø 142, 126*
Ø outer, 136 x 8 mm	Leadthrough for outer Ø	Ø 111, 91*, 76*

* with additional centering ring

Not available in Switzerland

Distribution chamber

Installation for dimensions CPX 25/76 - 125/182

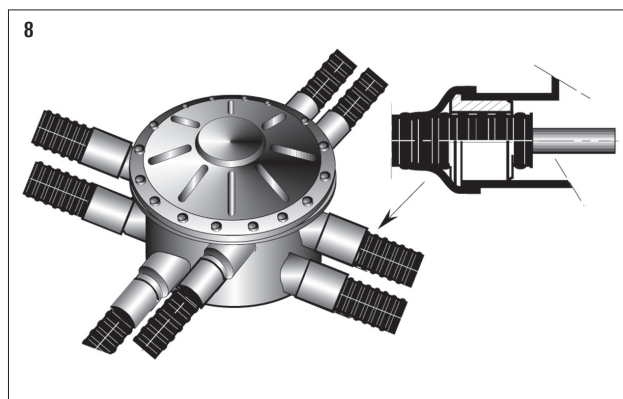
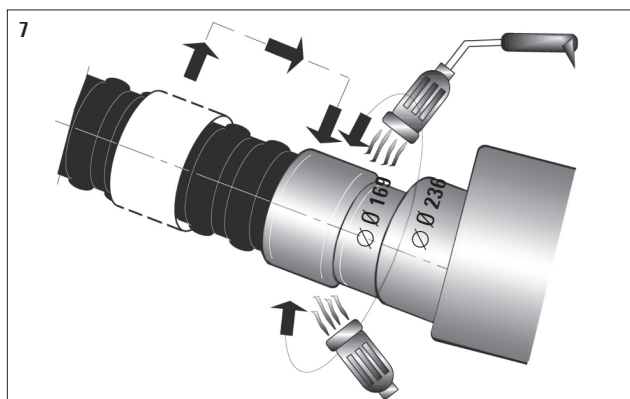
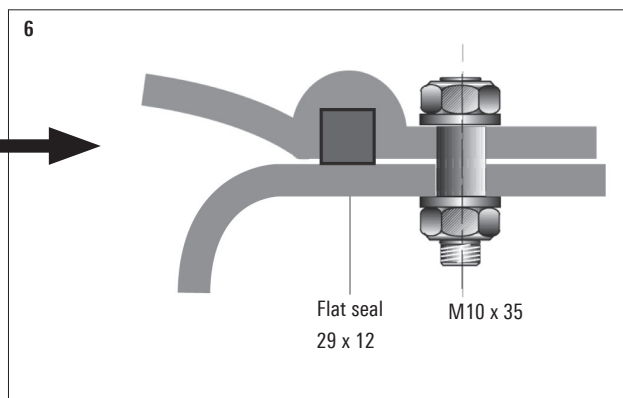
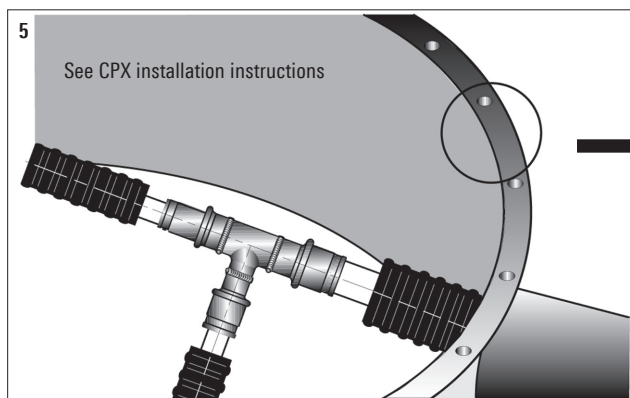
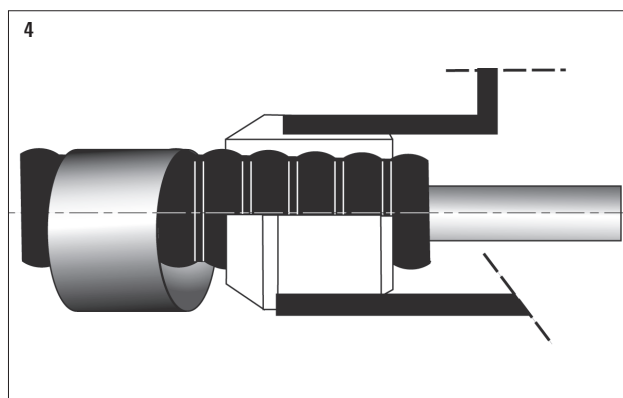
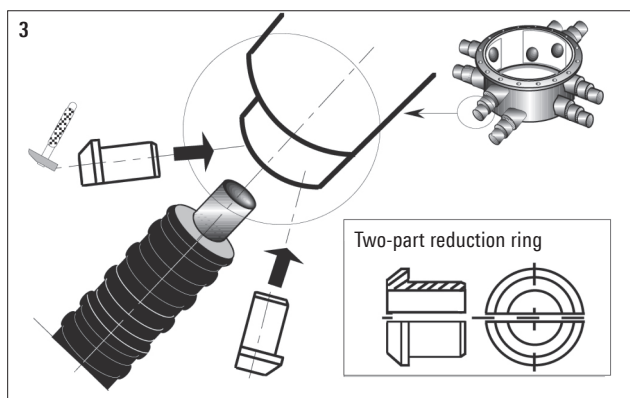
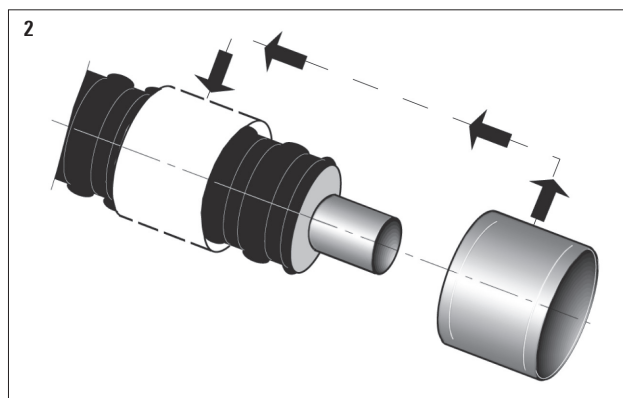
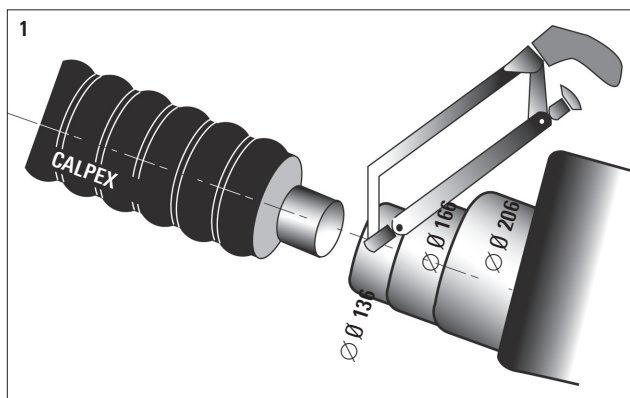

Protective concrete plate

for distribution chamber

Schematic diagram showing installation of cover plate

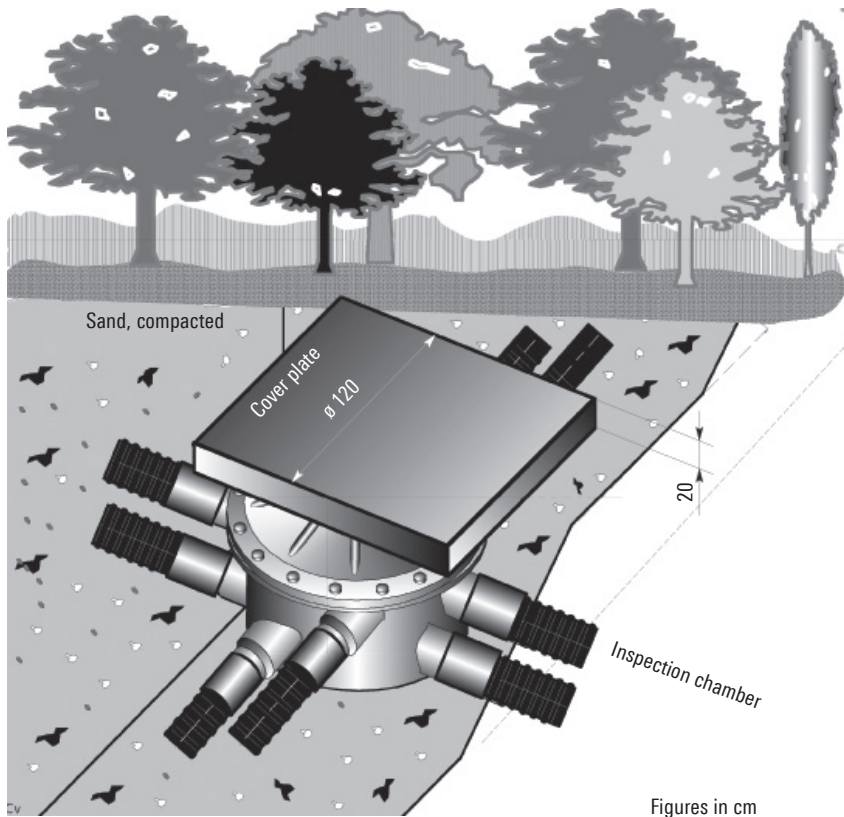

Figures in cm

Load

The cover plate has to be used wherever there might be public traffic and for low-depth installations. The maximum load per unit of area must not exceed $q = 153 \text{ kN/m}^2$ (SLW 60 to DIN 1055).

Installation method

Correct installation of the sand must be ensured so that the plate can perform its function as a load shield for the inspection chamber. A Proctor density of $dpr = 96\%$ should be the target for compaction. For subsequent work on the inspection chamber, the cover plate has lifting eyes. After completing the work and refilling the pit, make sure that the infill between the inspection chamber and concrete slabs is restored correctly.

Filling/insulation material

Some suggestions for filling and insulation materials that can be used are listed below:

- Bulk polystyrene material
- Armaflex or Tubolit
- Foam using BRAG PUR foam canister

Note

There is no need to use filling material in the distribution shaft. Likewise, it is not essential to insulate the pipes! The decision is up to the customer.

Note

The plate must be located so that it completely covers the chamber below (see illustration).

Armouring

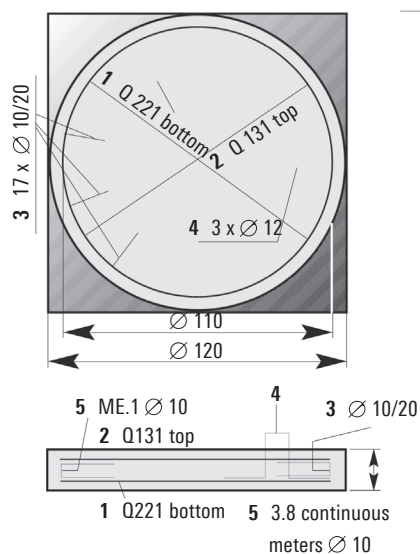

Figures in cm

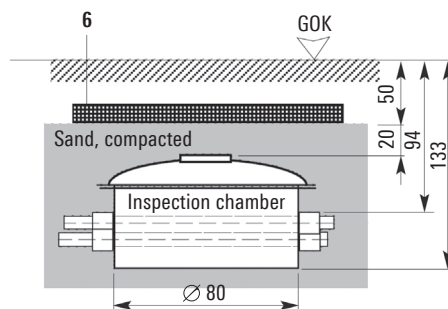

- 1 Q 221 bottom
- 2 Q 131 bottom
- 3 17 x Ø 10/20 mm (L = 0.5 m)
Total length 8.5 m
- 4 3 x Ø 12 mm (L = 0.85 m)
Total length 2.55 m

$$7.5 \frac{21}{21.5}$$

$$\frac{21}{16} \frac{12}{15}$$

Insulation material

PE foam (CPX 25/76 - 110/182), PUR foam container(s)

PUR foam bottles (CPX 25/76 - 160/250)

Insulation material for shrink joints

Polyethylene foam tube, (CPX 25/76 - 110/182)

Extruded pipe insulation made of closed-cell polyethylene, excellent for insulating CALPEX shrink joints (not for CALPEX shells). Various thicknesses of insulation are available for the most common pipe diameters.

The insulation material (thickness and length) is supplied for the relevant joint types.

The insulation must be fitted precisely into the joints on site.

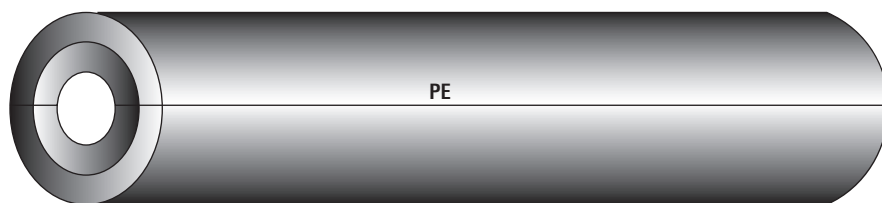

PUR foam for shrink joints and CALPEX shells (CPX 25/76 - 160/250)

CFC-free, cyclopentane-blown PUR foam in plastic bottles

The required quantity of CFC-free polyurethane foam is delivered in suitable container sizes for the various joints and T-pieces. The components are supplied separately in two bottles and are only mixed together when needed. Please note the safety regulations in the installation instructions supplied with the product.



Safety regulations

Protective goggles and gloves must be worn when using this product.

Synthetic gloves

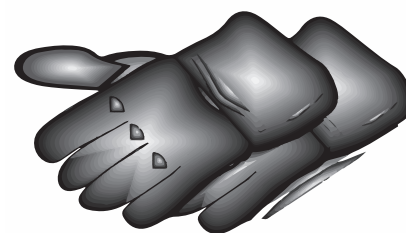

Protective goggles



Screwed connectors

Outer thread, weld end

Connection with external thread

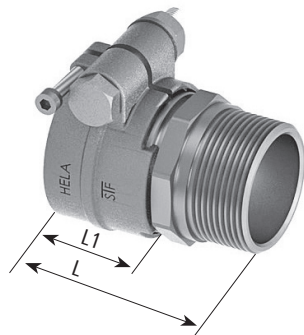

CALPEX PUR-KING (Heating, 6 bar)			CALPEX SANITARY (Sanitary, 10 bar)		
Material: brass			Material: brass		
PEX pipe mm	Screwed connector mm	L/L1 mm	PEX pipe mm	Screwed connector mm	L/L1 mm
25 x 2.3	25 x 2.3-3/4"	61/26	20 x 2.8	20 x 2.8-3/4"	61/26
32 x 2.9	32 x 2.9-1"	68/29	25 x 3.5	25 x 3.5-3/4"	63/29
40 x 3.7	40 x 3.7-1 1/4"	77/36	32 x 4.4	32 x 4.4-1"	68/29
50 x 4.6	50 x 4.6-1 1/2"	79/36	40 x 5.5	40 x 5.5-1 1/4"	79/36
63 x 5.7	63 x 5.7-2"	97/46	50 x 6.9	50 x 6.9-1 1/2"	79/36
75 x 6.8	75 x 6.8-2 1/2"	107/53	63 x 8.7	63 x 8.7-2"	97/46
90 x 8.2	90 x 8.2-3"	119/58	75 x 10.3	75 x 10.3-2 1/2"	101/53
110 x 10.0	110 x 10.0-4"	135/70	90 x 12.3	90 x 12.3-3"	116/58
125 x 11.4	125 x 11.4-5"	144/69	110 x 15.1	110 x 15.1-4"	135/70
140 x 12.7	140 x 12.7-5"	145/70	125 x 17.1	125 x 17.1-5"	136/69
160 x 14.6	160 x 14.6-6"	145/70			

Connection with weld end

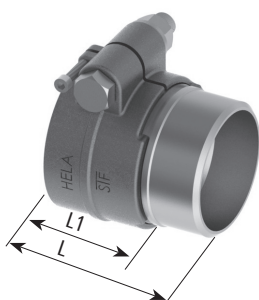

CALPEX PUR-KING (Heating, 6 bar)		
Material: brass		
PEX pipe mm	Weld end mm	L/L1 mm
25 x 2.3	26.9 x 2.3	61/26
32 x 2.9	33.7 x 2.6	63/29
40 x 3.7	42.4 x 2.6	75/36
50 x 4.6	48.3 x 2.6	84/36
63 x 5.7	60.3 x 2.9	88/46
75 x 6.8	76.1 x 2.9	101/53
90 x 8.2	88.9 x 3.2	108/58
110 x 10.0	114.3 x 3.6	114/70
125 x 11.4	114.3 x 3.6	120/69
140 x 12.7	139.7 x 3.6	120/75
160 x 14.6	168.3 x 4.1	145/70

CALPEX PUR-KING (Heating, 10 bar)		
Material: brass		
PEX pipe mm	Weld end mm	L/L1 mm
32 x 4.4	33.7 x 2.6	63/29
40 x 5.5	42.4 x 2.6	75/36
50 x 6.9	48.3 x 2.6	84/36
63 x 8.7	60.3 x 2.9	88/46
75 x 10.3	76.1 x 2.9	101/53
90 x 12.3	88.9 x 3.2	108/58
110 x 15.1	114.3 x 3.6	114/70
125 x 17.1	114.3 x 3.6	120/69

Note: We only recommend using press connections (CPX 1.385 - 1.395) in the soil

Screwed connector

Coupling: equal, elbow 90°

Coupling, equal

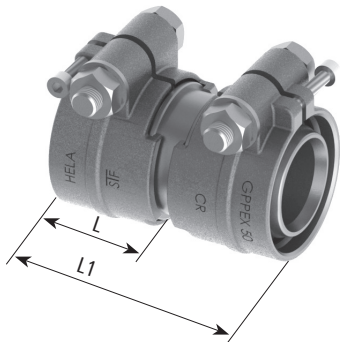

Heating, 6 bar Material: brass			Sanitary, 10 bar Material: brass		
PEX pipe mm	Coupling mm	L/L1 mm	PEX pipe mm	Coupling mm	L/L1 mm
25 x 2.3	25 x 2.3	68/26	20 x 3.0	20 x 2.8	68/26
32 x 2.9	32 x 2.9	75/29	25 x 3.5	25 x 3.5	72/29
40 x 3.7	40 x 3.7	90/36	32 x 4.4	32 x 4.4	75/29
50 x 4.6	50 x 4.6	90/36	40 x 5.5	40 x 5.5	90/36
63 x 5.7	63 x 5.7	110/46	50 x 6.9	50 x 6.9	90/36
75 x 6.8	75 x 6.8	128/52	63 x 8.7	63 x 8.7	110/46
90 x 8.2	90 x 8.2	144/58	75 x 10.3	75 x 10.3	128/52
110 x 10.0	110 x 10.0	168/70	90 x 12.3	90 x 12.3	144/58
125 x 11.4	125 x 11.4	167/69	110 x 15.1	110 x 15.1	168/70
140 x 12.7	140 x 12.7	-	125 x 17.1	125 x 17.1	167/69
160 x 14.6	160 x 14.6	168/70			

On request reduced couplings (soldered) are available

Elbow 90°



Heating, 6 bar Material: brass soldered		Sanitary, 10 bar Material: brass soldered	
PEX pipe mm	on PEX pipe mm	PEX pipe mm	on PEX pipe mm
25 x 2.3	25 x 2.3	20 x 2.8	20 x 2.8
32 x 2.9	32 x 2.9	25 x 3.5	25 x 3.5
40 x 3.7	40 x 3.7	32 x 4.4	32 x 4.4
50 x 4.6	50 x 4.6	40 x 5.5	40 x 5.5
63 x 5.7	63 x 5.7	50 x 6.9	50 x 6.9
75 x 6.8	75 x 6.8	63 x 8.7	63 x 8.7
90 x 8.2	90 x 8.2	75 x 10.3	75 x 10.3
110 x 10.0	110 x 10.0	90 x 12.3	90 x 12.3
125 x 11.4	125 x 11.4	110 x 15.1	110 x 15.1
140 x 12.7	140 x 12.7	125 x 17.1	125 x 17.1

Note: We only recommend using press connections (CPX 1.385 - 1.395) in the soil

Compression connectors

Outer thread, weld end

Connector with external thread

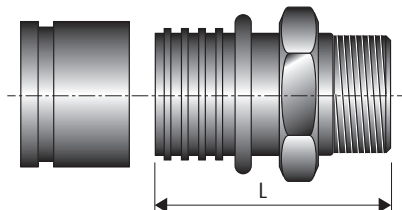

CALPEX PUR-KING (Heating, 6 bar)			CALPEX SANITARY (Sanitary, 10 bar)		
Material: brass			Material: brass		
PEX pipe mm	Screwed connector mm	L mm	PEX pipe mm	Screwed connector mm	L mm
25 x 2.3	25 x 2.3-3/4"	62	20 x 2.8	20 x 2.8-3/4"	58
32 x 2.9	32 x 2.9-1"	72	25 x 3.5	25 x 3.5-3/4"	62
40 x 3.7	40 x 3.7-1 1/4"	82	32 x 4.4	32 x 4.4-1"	72
50 x 4.6	50 x 4.6-1 1/2"	89	40 x 5.5	40 x 5.5-1 1/4"	82
63 x 5.8	63 x 5.7-2"	109	50 x 6.9	50 x 6.9-1 1/2"	89
75 x 6.8	75 x 6.8-2 1/2"	110	63 x 8.7	63 x 8.7-2"	109
90 x 8.2	90 x 8.2-3"	115			
110 x 10.0	110 x 10.0-4"	120			
125 x 11.4	125 x 11.4-5"	125			
160 x 14.6	160 x 14.6-6"	130			

Connector with weld end

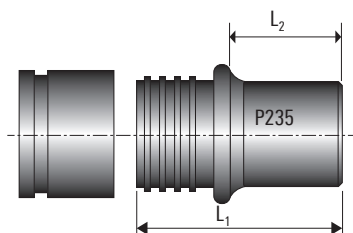

CALPEX PUR-KING (Heating, 6 bar)			
Material: Steel (P235)			
PEX pipe mm	Weld end mm	L1 mm	L2 mm
25 x 2.3	26.9 x 2.65	50	20
32 x 2.9	33.7 x 2.3	60	24
40 x 3.7	42.4 x 2.6	70	29
50 x 4.6	48.3 x 2.6	85	37
63 x 5.8	60.3 x 2.9	90	32
75 x 6.8	76.1 x 3.2	95	35
90 x 8.2	88.9 x 3.2	95	35
110 x 10.0	114.3 x 3.6	90	30
125 x 11.4	139.7 x 3.6	108	48
140 x 12.7	139.7 x 3.6	112	50
160 x 14.6	168.3 x 4.1	114	50

Press tools see CPX 1.540

Compression connectors

Coupling: equal, coupling: reduced, angle piece: 90°

Coupling

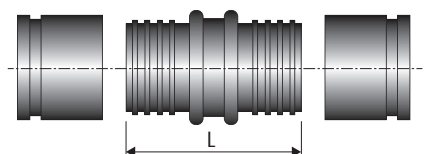

CALPEX PUR-KING (Heating, 6 bar)			CALPEX SANITARY (Sanitary, 10 bar)		
Material: brass			Material: brass		
PEX pipe mm	Coupling mm	L mm	PEX pipe mm	Coupling mm	L mm
25 x 2.3	25 x 2.3	67.0	20 x 2.8	20 x 2.8	58
32 x 2.9	32 x 2.9	88.0	25 x 3.5	25 x 3.5	70
40 x 3.7	40 x 3.7	100.0	32 x 4.4	32 x 4.4	82
50 x 4.6	50 x 4.6	114.0	40 x 5.5	40 x 5.5	90
63 x 5.8	63 x 5.7	141.0	50 x 6.9	50 x 6.9	104
75 x 6.8	75 x 6.8	137.5	63 x 8.7	63 x 8.7	122
90 x 8.2	90 x 8.2	137.5			
110 x 10.0	110 x 10.0	137.5			
125 x 11.4	125 x 11.4	141.0			
140 x 12.7	140 x 12.7	140.0			
160 x 14.6	160 x 14.6	149.0			

Coupling, reduced

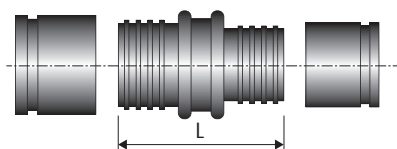

CALPEX PUR-KING (Heating, 6 bar)			CALPEX SANITARY (Sanitary, 10 bar)		
Material: brass/steel* (P235)			Material: brass		
PEX pipe mm	Coupling mm	L mm	PEX pipe mm	Coupling mm	L mm
32 x 2.9	25 x 2.3	80.0	32 x 4.4/25 x 3.5	32 x 4.4/25 x 3.5	76
40 x 3.7	32 x 2.9	100.0	40 x 5.5/32 x 4.4	40 x 5.5/32 x 4.4	86
50 x 4.6	40 x 3.7	108.0	50 x 6.9/40 x 5.5	50 x 6.9/40 x 5.5	97
63 x 5.8	50 x 4.6	129.0	63 x 8.7/50 x 6.9	63 x 8.7/50 x 6.9	113
75 x 6.8	63 x 5.8	138.0			
90 x 8.2	75 x 6.8	142.0			
110 x 10.0	90 x 8.2	142.0			
125 x 11.4*	110 x 10.1	228.0			
140 x 12.7*	125 x 11.4	220.0			
160 x 14.6*	125 x 11.4	262.0			

Angle piece, 90°

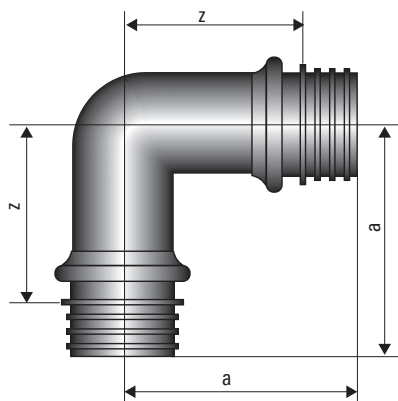

CALPEX PUR-KING (Heating, 6 bar)				CALPEX SANITARY (Sanitary, 10 bar)			
Material: brass/steel* (P235)				Material: brass			
PEX pipe mm	PEX pipe mm	a mm	z mm	PEX pipe mm	PEX pipe mm	a mm	z mm
25 x 2.3	25 x 2.3	54	32	20 x 2.8	20 x 2.8	-	-
32 x 2.9	32 x 2.9	64	37	25 x 3.5	25 x 3.5	-	-
40 x 3.7	40 x 3.7	74	42	32 x 4.4	32 x 4.4	66	39
50 x 4.6	50 x 4.6	87	48	40 x 5.5	40 x 5.5	74	42
63 x 5.8	63 x 5.8	106	60	50 x 6.9	50 x 6.9	87	39
75 x 6.8	75 x 6.8	117	67	63 x 8.6	63 x 8.6	106	60
90 x 8.2	90 x 8.2	127	76				
110 x 10.0	110 x 10.0	137	87				
125 x 11.4*	125 x 11.4	298	260				

Press tools see CPX 1.540

Compression connectors

T-piece

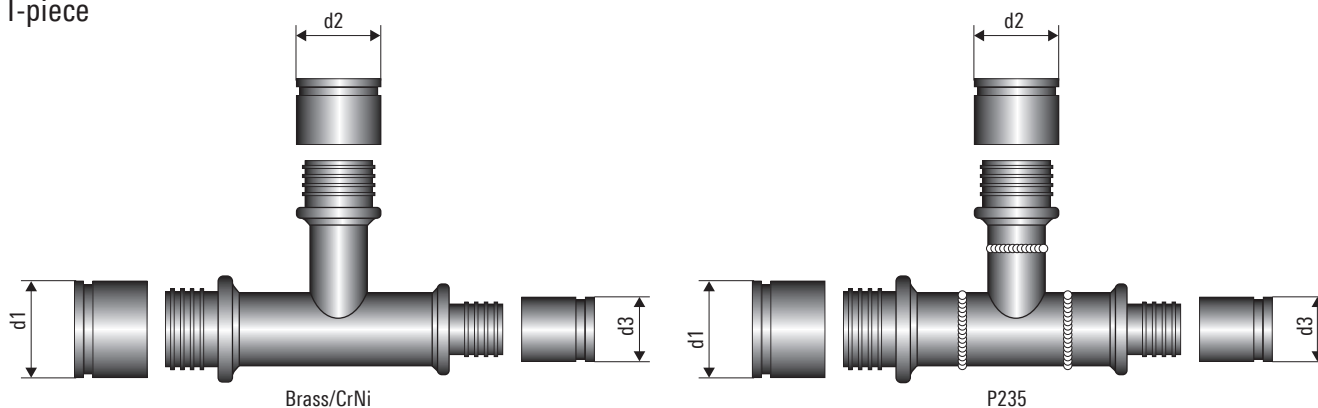

CALPEX PUR-KING (Heating, 6 bar)

Ø d1 Ø d3 mm	Branch, Ø d2									
	mm									
	25 x 2.3	32 x 2.9	40 x 3.7	50 x 4.6	63 x 5.8	75 x 6.8	90 x 8.2	110 x 10.0	125 x 11.4	
25 x 2.3 - 25 x 2.3	o/x									
32 x 2.9 - 32 x 2.9	o/x	o/x								
32 x 2.9 - 25 x 2.3	o/x									
40 x 3.7 - 40 x 3.7	o/x	o/x	o/x							
40 x 3.7 - 32 x 2.9	o/x ¹	o/x ¹								
50 x 4.6 - 50 x 4.6	o/x	o/x	o/x	o/x						
50 x 4.6 - 40 x 3.7	o/x	o/x	o/x ¹							
63 x 5.8 - 63 x 5.8	o/x	o/x	o/x	o/x	o/x					
63 x 5.8 - 50 x 4.6	o/+	o/x	o/x	o/x						
75 x 6.8 - 75 x 6.8	o/x	o/x	o/x	o/x	o/x	o/x				
75 x 6.8 - 63 x 5.8	o/+	o/x	o/+	o/x	o/x					
90 x 8.2 - 90 x 8.2	o/+	o/x	o/x	o/+	o/x	o/+	o/x			
90 x 8.2 - 75 x 6.8	o/+	o/+	o/+	o/+	o/+	o/+				
110 x 10.0 - 110 x 10.0	o/+	o/x	o/+	o/x	o/x	o/+	o/+	o/x		
110 x 10.0 - 90 x 8.2	o/+	o/+	o/+	o/+	o/+	o/+	o/+			
125 x 11.4-125 x 11.4	o/+	o/+	o/+	o/+	o/+	o/+	o/+	o/+	o/+	o/+
125 x 11.4-110 x 10.0	o/+	o/+	o/+	o/+	o/+	o/+	o/+	o/+	o/+	o/+

¹ Soldered fittings

- T-pieces made of steel can be supplied on request
- Other T-pieces can be supplied on request.
- Dimension DN 150 is supplied in prefabricated and pre-insulated form (see sheet CPX 1.340).

Material:

- x = Brass CuZn39Pb3 (DN 20 - DN 50),
Gunmetal Rg7 (DN 65 - DN 100)
- o = P235, welded
- + = CrNi 1.4404, 1.4432, 1.4435 (316L)

Compression connectors

T-piece

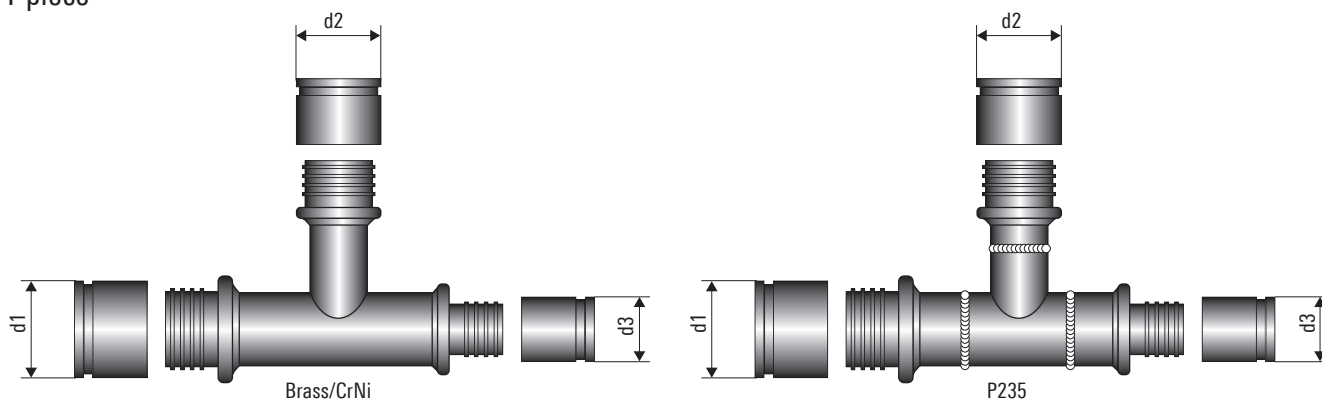

CALPEX SANITARY (Sanitary, 10 bar)

ø d1 ø d3 mm	Branch, ø d2					
	mm					
	20 x 2.8	25 x 3.5	32 x 4.4	40 x 5.5	50 x 6.9	63 x 8,7
20 x 2.8- 20 x 2.8	x	x				
25 x 3.5- 25 x 3.5	x	x	x	x		
32 x 4.4- 32 x 4.4	x	x	x	x		
32 x 4.4- 25 x 3.5	x	x	x	x		
40 x 5.5- 40 x 5.5	x	x	x	x	x	
40 x 5.5- 32 x 3.0	x	x	x	x		
40 x 5.5- 25 x 3.5	x			x	x	
50 x 6.9- 50 x 6.9	x	x	x	x	x	
50 x 6.9- 40 x 5.5	x	x	x	x	x	
50 x 6.9- 32 x 4.4	x	x	x	x	x	
50 x 6.9- 25 x 3.5		x		x	x	
63 x 8.7- 63 x 8.7	x	x	x	x	x	x
63 x 8.7- 50 x 6.9		x	x	x	x	
63 x 8.7- 40 x 5.5		x		x	x	x

¹ Soldered fittings

- T-pieces made of steel can be supplied on request
- Other T-pieces can be supplied on request.
- Dimension DN 150 is supplied in prefabricated and pre-insulated form (see sheet CPX 1.340).

Material:

- x = Brass CuZn39Pb3 (DN 20 - DN 50),
Gunmetal Rg7 (DN 65 - DN 100)
- o = P235, welded
- + = CrNi 1.4404, 1.4432, 1.4435 (316L)

Electro-fusion joints

Dimensions Ø 75 - 160 mm

Coupling



CALPEX PUR-KING (Heating, 6 bar)	
Material: cross-linked polyethylene	
PEX pipe mm	PEX pipe mm
50 x 4,6	50 x 4,6
63 x 5,8	63 x 5,8
75 x 6,8	75 x 6,8
90 x 8,2	90 x 8,2
110 x 10,0	110 x 10,0
125 x 11,4	125 x 11,4
160 x 14,6	160 x 14,6

Angle piece, 90°



CALPEX PUR-KING (Heating, 6 bar)	
Material: cross-linked polyethylene	
PEX pipe mm	PEX pipe mm
75 x 6,8	75 x 6,8
90 x 8,2	90 x 8,2
110 x 10,0	110 x 10,0
125 x 11,4	125 x 11,4

Transition sleeve/joint with flange (AG)



CALPEX PUR-KING (Heating, 6 bar)	
Material: cross-linked polyethylene	
PEX pipe mm	PEX pipe mm
75 x 6,8	75 x 6,8
90 x 8,2	90 x 8,2
110 x 10,0	110 x 10,0
125 x 11,4	125 x 11,4

Reduction piece*



CALPEX PUR-KING (Heating, 6 bar)	
Material: cross-linked polyethylene	
PEX pipe mm	PEX pipe mm
90	75
110	75
110	90
125	75
125	90
125	110
160	75
160	90
160	110
160	125

T-piece, equal



CALPEX PUR-KING (Heating, 6 bar)	
Material: cross-linked polyethylene	
PEX pipe mm	PEX pipe mm
50 x 4,6	50 x 4,6
63 x 5,8	63 x 5,8
75 x 6,8	75 x 6,8
90 x 8,2	90 x 8,2
110 x 10,0	110 x 10,0
125 x 11,4	125 x 11,4

*Note: Reductions cannot be used when using CALPEX clip shells.

Leasable basic tool for PEXa electro-fusion joints
comprising welding machine and pipe clamps



Article	
Tool set without pipe cutter	
Additional pipe clamps-set	
Pipe cutter 50-125 mm	
Pipe cutter 110-160 mm	

Only trained personnel, using suitable fusion equipment, may install the electrofusion joints for PEXa connections.

End cap

Standard, shrinkable

Shrink-on end cap, UNO

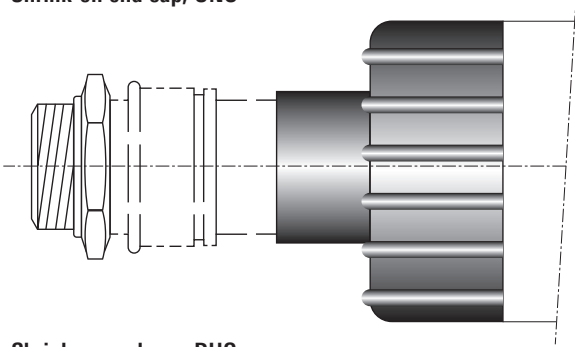

End cap, UNO (LD-PE)

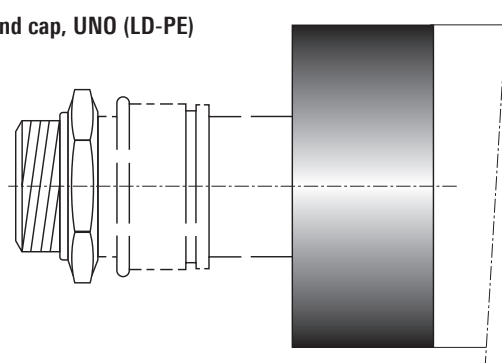

Shrink-on end cap, DUO

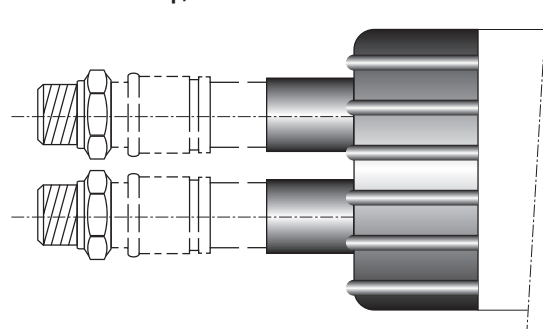

End cap, DUO (LD-PE)

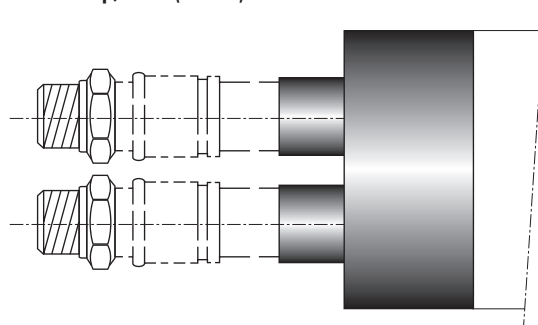

Shrink-on end cap, QUADRIGA

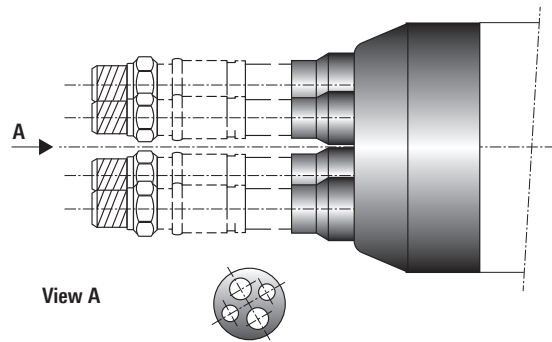

End cap, QUADRIGA (LD-PE)

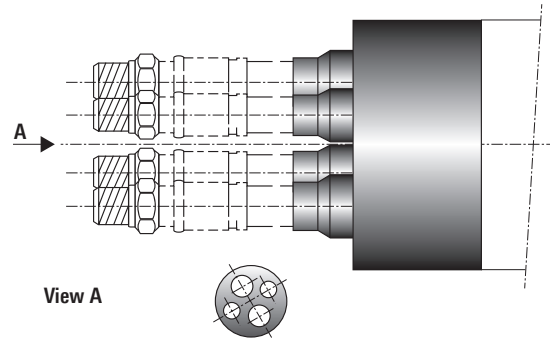

CALPEX UNO	
Type Heating	Type Sanitary
5/ 76	20/ 76
25/ 91 PLUS	25/ 76
32/ 76	32/ 76
32/ 91 PLUS	32/111 HBK
40/ 91	40/ 91
40/111 PLUS	40/126 HBK
50/111	50/111
50/126 PLUS	50/126 HBK
63/126	63/126
63/142 PLUS	
75/142	
75/162 PLUS	
90/162	
90/182 PLUS	
110/162	
110/182	
125/182	
125/202 PLUS	
140/202	

CALPEX DUO	
Type	
25 + 25/ 91	
25 + 25/111 PLUS	
25 + 20/ 91	
32 + 20/111	
32 + 32/111	
32 + 32/126 PLUS	
40 + 25/126	
40 + 40/126	
40 + 40/142 PLUS	
50 + 32/126	
50 + 50/162	
50 + 50/182 PLUS	
63 + 63/182	
63 + 63/202 PLUS	
75 + 75/202	

QUADRIGA	
Type	
25 + 25/25 + 20/142	
32 + 32/25 + 20/142	
32 + 32/32 + 20/142	
40 + 40/40 + 25/162	

LD-PE end caps are fitted on;
suitable for dry rooms

Wall sealing ring

for wall openings

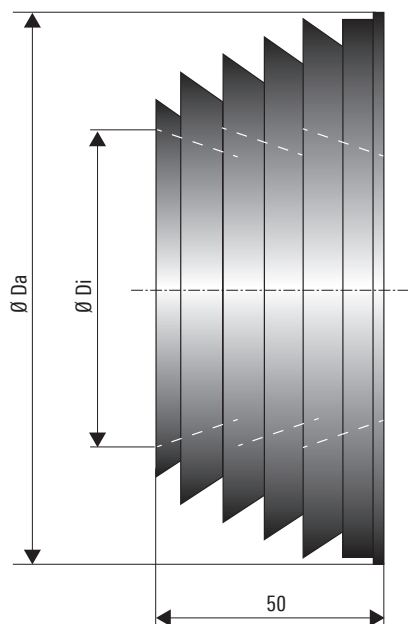

Figures in mm

CALPEX UNO, DUO, QUADRIGA

Outer casing diameter mm	Neoprene wall sealing ring Ø Di, inner mm	Ø Da, outer mm
76	74	118
91	88	133
111	107	153
126	122	168
142	137	183
162	155	203
182	175	223
202	195	230
225	180	240
250	243	290

Building entry (see sheet CPX 1.415)

Building entry

Wall opening

Wall leadthrough

PEX connection piece:
see sheet 1.370
or sheet 1.390

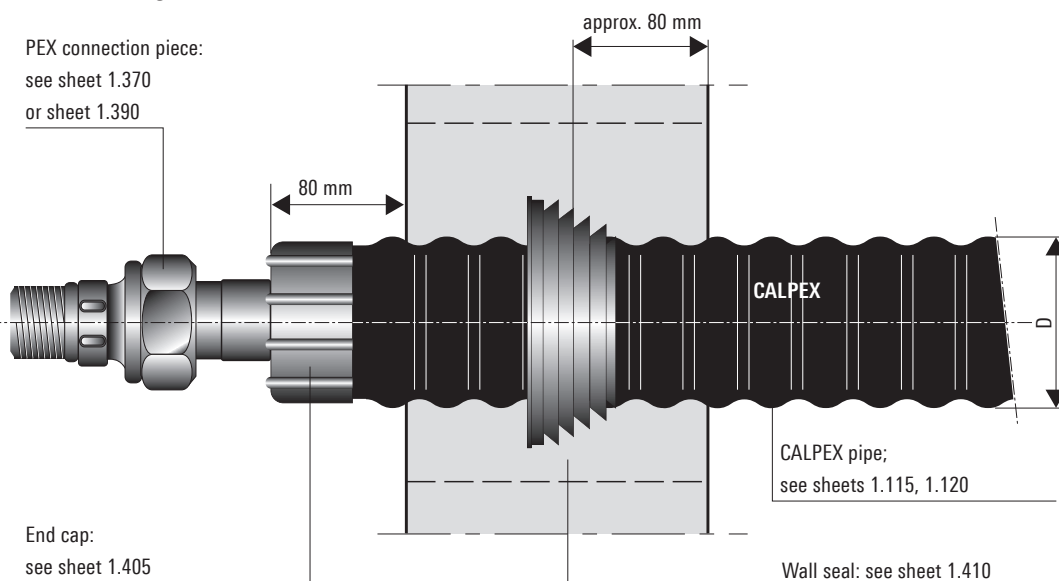

End cap:
see sheet 1.405

Wall opening

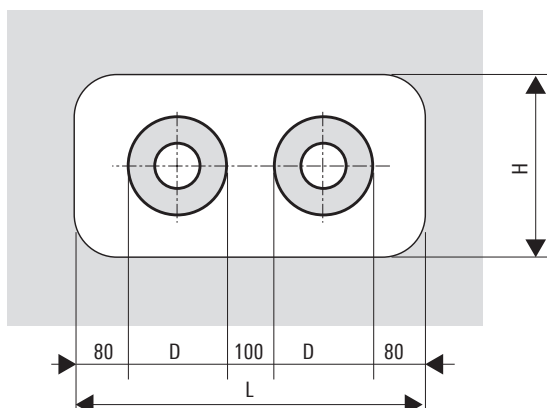

Figures in mm

Outer casing Ø D mm	L min mm	H min mm
78	450	250
93	500	250
113	500	300
128	550	300
143	600	350
163	650	350
183	670	380
202	720	400
225	740	400
250	810	450

Core bores

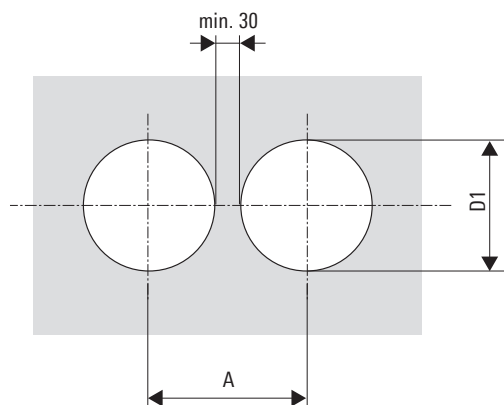

Figures in mm

Outer casing Ø D mm	A mm	D1 mm
78	210	180
93	230	180
113	250	230
128	270	230
143	290	230
163	310	280
183	330	280
202	400	350
225	400	350
250	420	380

Wall seal

Core bores/cement liner pipes

Standard

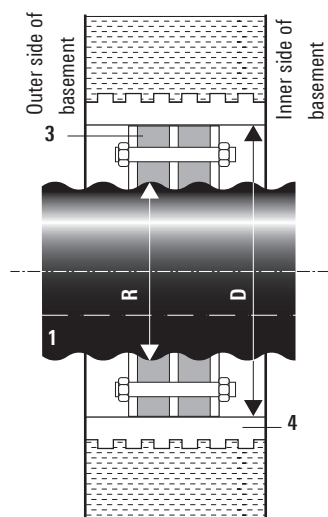

With additional centering ring

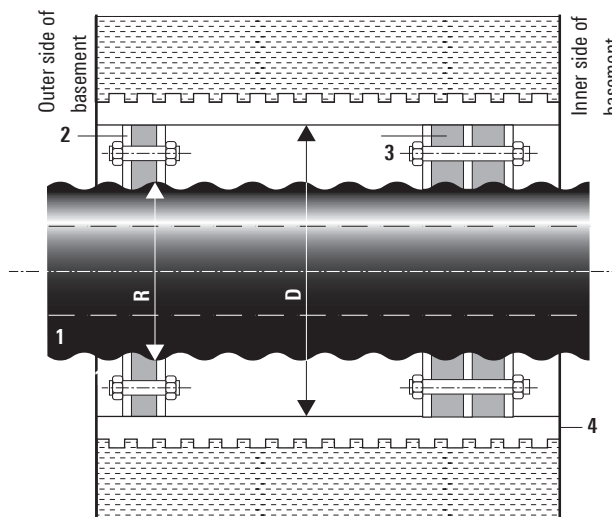

Core bores

Perfect bores are required for installation. As hairline cracks may be present in the concrete or result from drilling, it is advisable to seal the entire length of the borehole with suitable sealant (such as AQUAGARD).

Tightness can only be guaranteed if this recommendation is followed.

Outer pipe Ø R mm	Liner pipe, core bore Ø D mm	Seal set Ø inner mm	Core bore Ø mm
76	150	78 - 85	150
91	150	86 - 94	150
111	200	105 - 115	200
126	200	125 - 135	200
142	200	137 - 145	200
162	250	157 - 165	250
182	250	180 - 190	250
202	300	198 - 207	300
225	300	225 - 233	300
250	350	250 - 259	350

Building entry (see sheet CPX 1.425)

- 1 CALPEX district heating pipe
- 2 Seal set, single-seal not suitable for pressure from water
1 x 40 mm, Shore hardness D 35
- 3 Seal set, double-seal* suitable for pressure from water up to 0.5 bar
2 x 40 mm, Shore hardness D 35
- 4 Liner pipe: made of fibre cement or coated core bore

Building entry

Core bores/cement pipe liners

Wall leadthrough

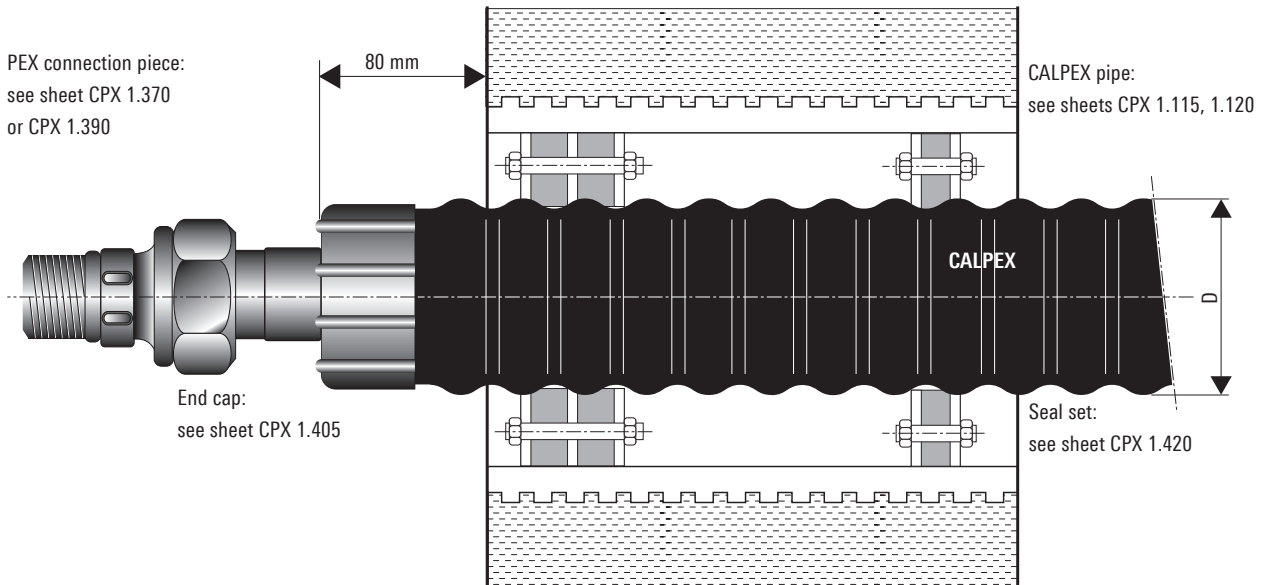

Core bores

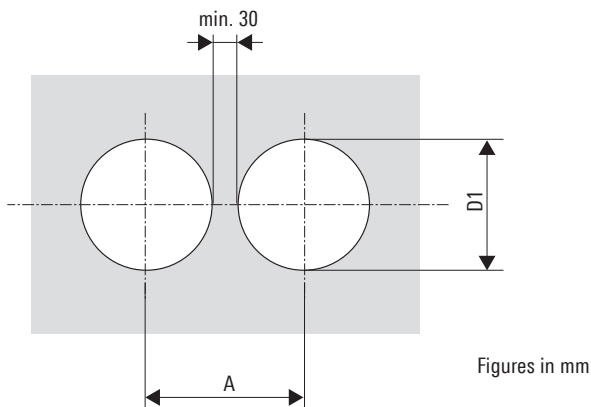

Outer casing Ø D mm	A mm	D1 mm
78	180	150
93	180	150
113	230	200
128	230	200
143	230	200
163	280	250
183	280	250
202	330	300
225	330	300
250	380	350

Pipe routing

CALPEX – Connection to insulated steel pipe

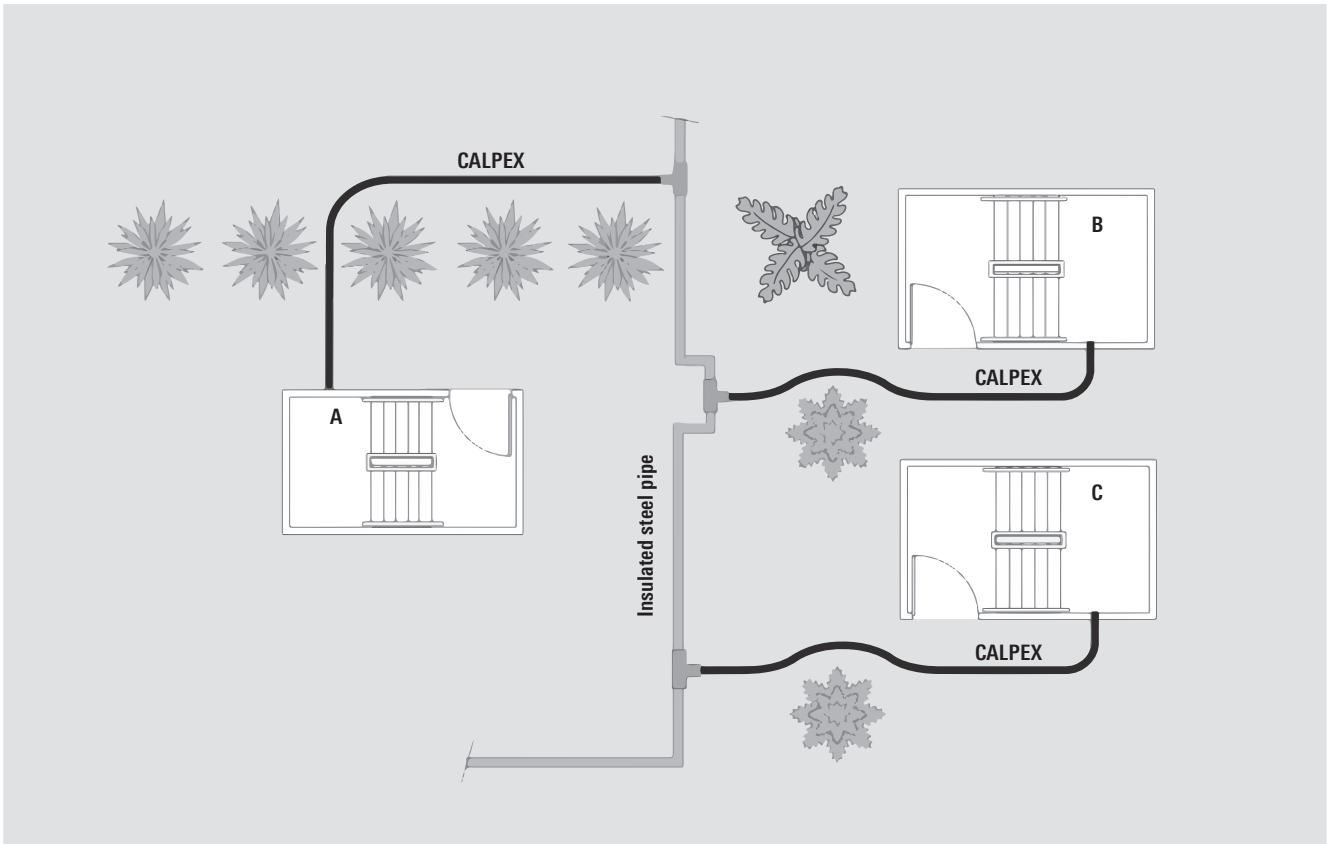

Loop-in method

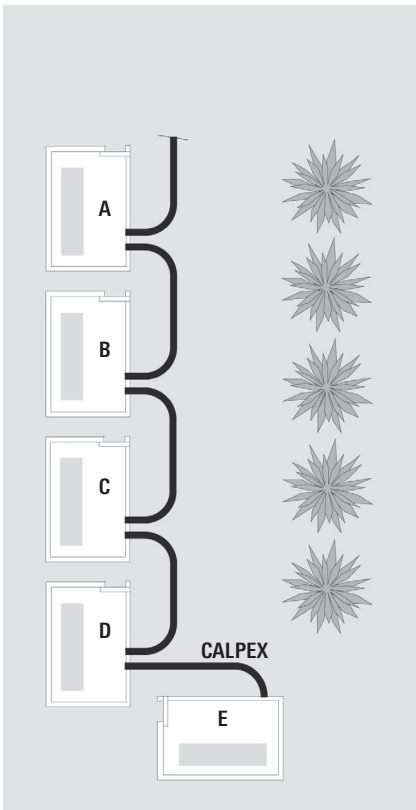

CALPEX – CALPEX connection

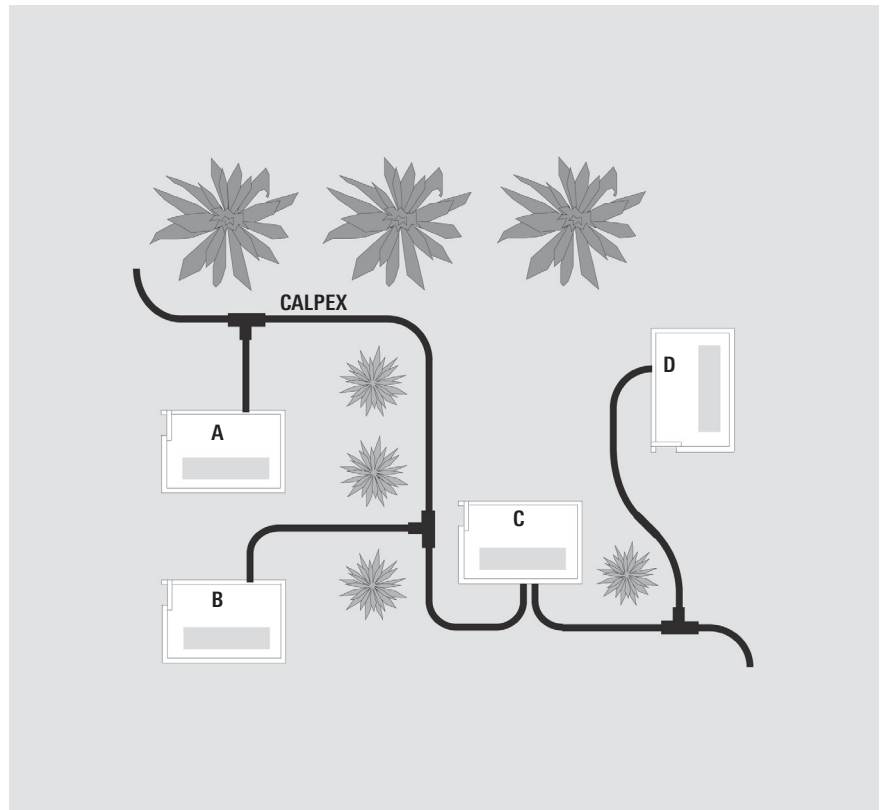

Trench dimensions

Trench profile, 2 CALPEX pipes

UNO

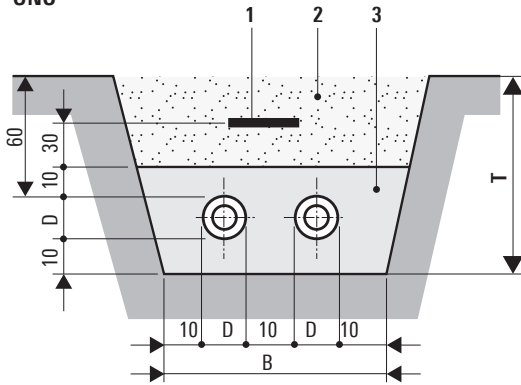

DUO, QUADRIGA

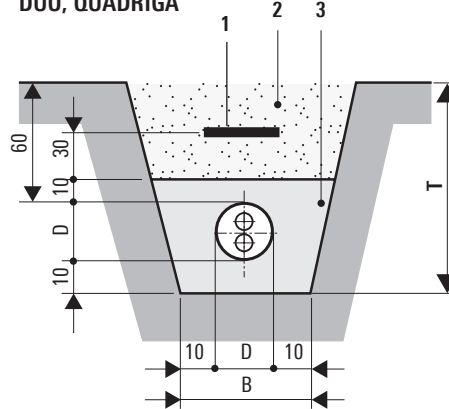

Figures in cm

Casing pipe Ø D mm	Width B cm	Depth T cm	Minimum bending radius m
78	45	80	0.7
93	50	80	0.8
113	55	85	0.9
128	55	85	1.0
143	60	85	1.1
163	65	90	1.2
183	70	95	1.4
202	75	95	1.4
250	80	100	-

Casing pipe Ø D mm	Width B cm	Depth T cm	Minimum bending radius m
93	30	80	0.8
113	30	85	0.9
128	35	85	1.0
143	35	85	1.1
163	35	90	1.2
183	38	95	1.4
202	40	95	1.4

Trench profile, 4 CALPEX pipes

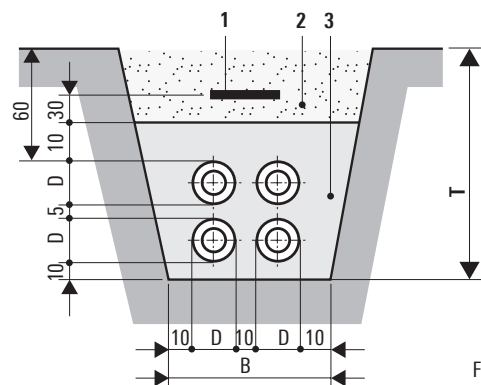
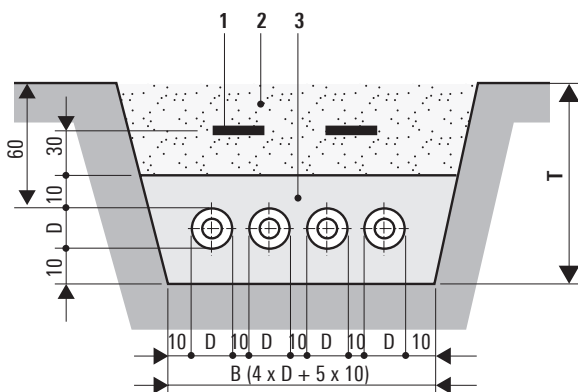

Figures in cm

- 1 Pipe warning tape; see sheet CPX 1.430
- 2 Excavated material
- 3 Fill material see below

Installation depth:
 Max. installation depth: 2.6 m
 Our approval is required for installation at greater depths.

SLW 30 $\hat{=}$ 300 kN total load as per DIN 1072; if subject to higher traffic loads (e.g. SLW 60), a load-distributing superstructure as per RSt075 is required.

With no traffic load, the minimum trench depth **T** can be reduced by 20 cm.

The fill material in the embedment must comply with EN 13941-2 and satisfy the following minimum requirements:

- Friable, round-edged sand-gravel mixture
- Permissible grain size: 0...8 mm
- Coefficient of uniformity according to DIN EN ISO 14688-2 larger than 1.8
- Maximum 10 percent by mass \leq 0.075 mm
- Maximum 3 percent by mass \leq 0.02 mm
- Proctor density min. 94%; optimal 97 up to 98%

Pipe warning tape

CALPEX pipe warning tape

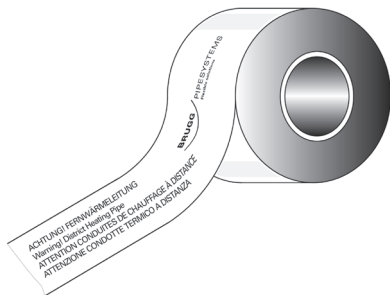

Pipe warning tape to be laid in the ground.
Roll length: 250 m

CALPEX trench structure

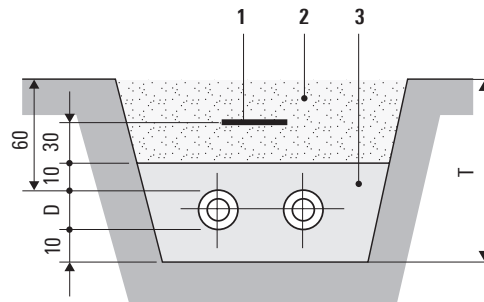

- 1 Pipe warning tape
- 2 Excavated material
- 3 Washed sand

Installation depth; see sheet CPX 1.505

Laying tools

Using the CALPEX unwinding device and the CALPEX – power winch makes it possible to easily and quickly unroll and lay the flexible composite pipe systems.

CALPEX-Unwinding device



Dimension: Ø 400 x 157 cm
Load capacity: 1'000 kg

Power winch



Our recommendation:
<https://www.portablewinch.com>

CALPEX-Squeezing device

for temporary closing up PE- and PEX-pipes

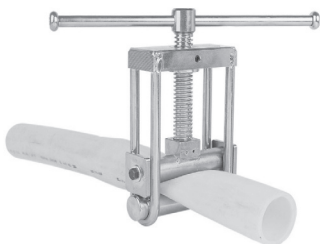

Squeezing device Ø 32 – 63 mm (SDR11)



Squeezing device Ø 75 - 160 mm (SDR11)

Connection (rigid/flexible)

CALPEX to insulated steel pipes

Installation instructions for transition from CALPEX to insulated steel pipe (KMR)

1. Junction with T-piece

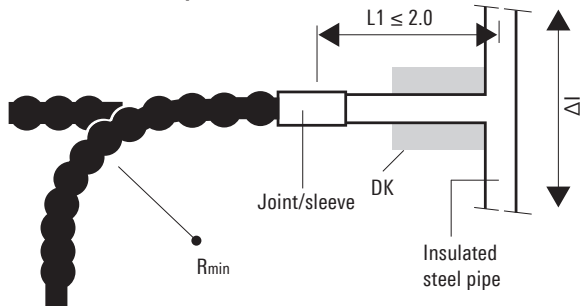

The transverse expansion ΔI must not exceed the expansion that can be accommodated by junction pipe DS and the CALPEX pipe.

2. Transition with fixed point

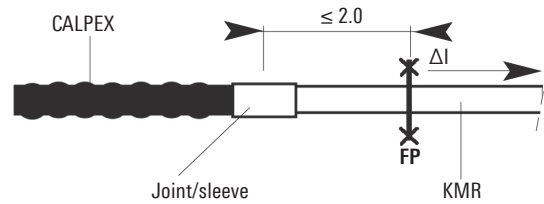

Figures in m

The thermal movement ΔI of the insulated steel pipe cannot be compensated by the CALPEX pipes. A fixed point must be installed.

3. Transition with Z-bend

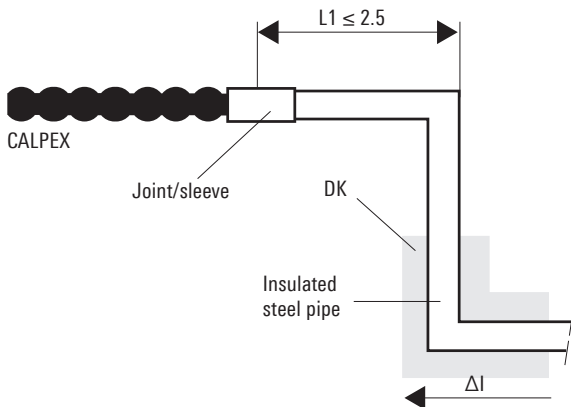

Static design of the Z-bend according to expansion variable ΔI .

- ΔI = Thermal movement
- FP = Fixed point (plastic casing pipe)
- DK = Expansion pad

4. Transition with expansion bend

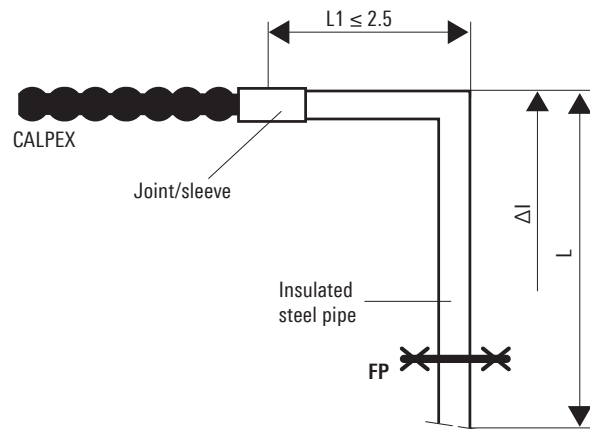

Figures in m

If pipe length L or ΔI is more than permitted for $L1$, a fixed anchor point must be installed.

- Design of expansion components
- Positioning of expansion pads as per the section on PREMANT

House entry, screwed connector/compression joint

Shaft entry

Connection with external thread

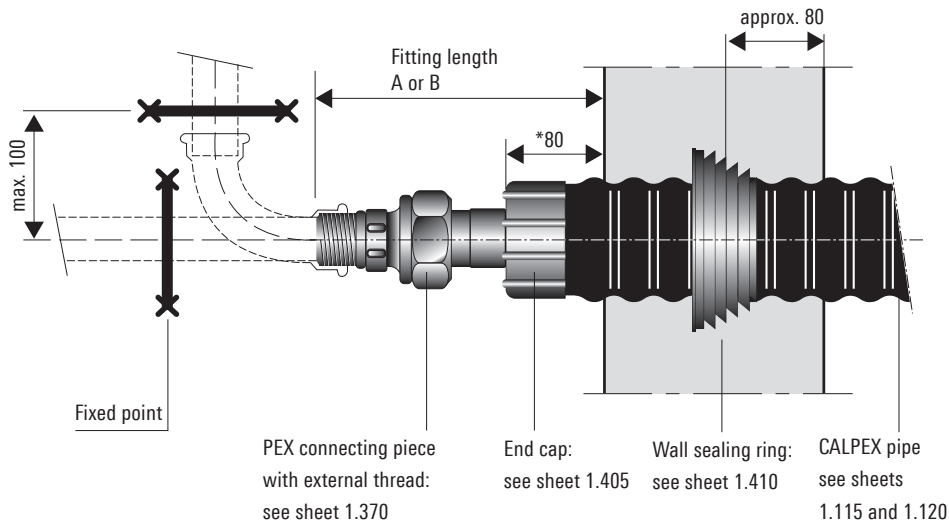

Figures in mm

Screwed connector

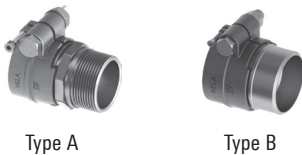

Type A

Type B

Compression joint

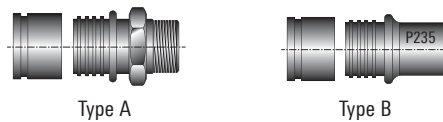

Type A

Type B

CALPEX PUR-KING		
Heating, 6 bar	Fitting lengths	
PEX-Pipe	A	B
mm	mm	mm
25 x 2.3	190	190
32 x 2.9	195	190
40 x 3.7	200	200
50 x 4.6	205	210
63 x 5.8	225	215
75 x 6.8	230	225
90 x 8.2	245	235
110 x 10.0	260	240
125 x 11.4	270	250
140 x 12.7	270	250
160 x 14.6	270	270
CALPEX SANITARY, 10 bar		
20 x 2.8	190	190
25 x 3.5	190	190
32 x 4.4	195	200
40 x 5.5	205	210
50 x 6.9	205	210
63 x 8.7	220	215
75 x 10.3	230	225
90 x 12.3	240	235
110 x 15.1	260	240
125 x 17.5	260	250

CALPEX PUR-KING		
Heating, 6 bar	Fitting lengths	
PEX-Pipe	A	B
mm	mm	mm
25 x 2.3	260	250
32 x 2.9	260	250
40 x 3.7	270	260
50 x 4.6	270	270
63 x 5.8	320	310
75 x 6.8	320	310
90 x 8.2	330	310
110 x 10.0	340	310
125 x 11.4	340	310
160 x 14.6	340	340
CALPEX SANITARY, 10 bar		
20 x 2.8	260	
25 x 3.5	260	
32 x 4.4	260	
40 x 5.5	270	
50 x 6.9	270	
63 x 8.7	320	

House entry, compression joint

Fixed point forces

Connection with external thread

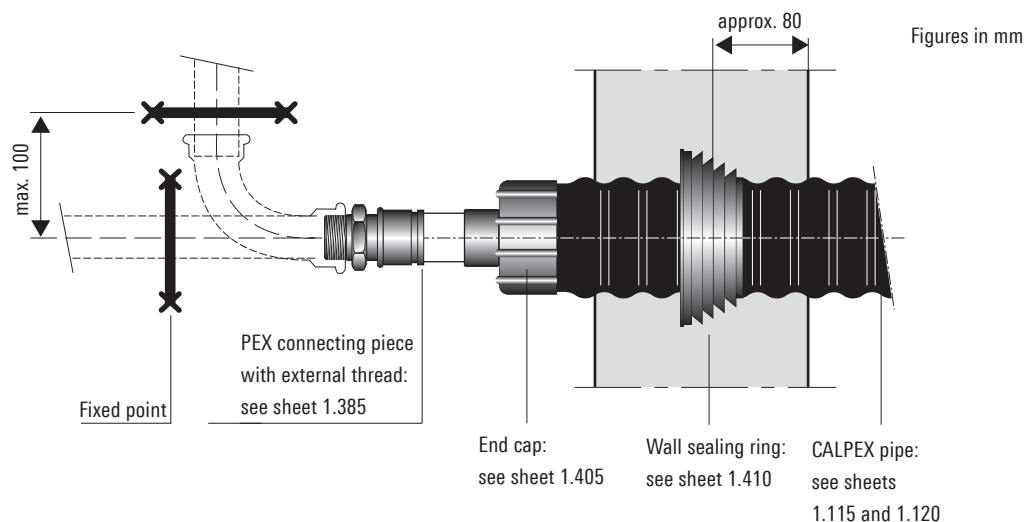

Fixed point forces occurring CALPEX PUR-KING (Heating, 6 bar)

Maximum fixed point forces occurring per pipe for:

Type	Type	Maximum fixed point forces occurring per pipe for:	
		TB = 60 °C, pB = 6 bar Fmax [N]	TB = 90 °C, pB = 6 bar Fmax [N]
25/ 76	25/ 91 PLUS	640	924
32/ 76	32/ 91 PLUS	1036	1493
40/ 91	40/111 PLUS	1639	2367
50/111	50/126 PLUS	2553	3686
63/126	63/142 PLUS	4013	5782
75/142	75/162 PLUS	5693	8205
90/162	90/182 PLUS	8228	11864
110/182	110/202 PLUS	12260	17675
125/182	125/202 PLUS	15872	22888
140/202		19928	28747
160/250		26004	37502

CALPEX SANITARY (Sanitary, 10 bar)

Maximum fixed point forces occurring per pipe for:

Maximum fixed point forces occurring per pipe for:		
TB = 60 °C, pB = 10 bar		
Typ	DN	Fmax [N]
20/ 76	16	820
25/ 76	20	1350
32/ 76	25	1730
40/ 91	32	2700
50/111	40	4230
63/126	50	6715

Fixed points

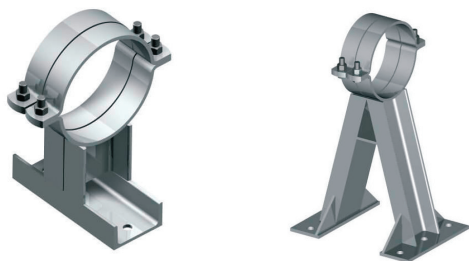

Installation of house entry



1 Mark the distance (x, y, z) + 1 cm from the end of the pipe.



2 Cut the casing pipe with saw.



3 Split the casing pipe with knife.
Note: Don't damage the carrier pipe!



4 Peel off the casing.



5 Cut back/remove the insulation along length (X, Y, Z).
Note: Don't damage the carrier pipe!



6 Install the wall sealing ring.

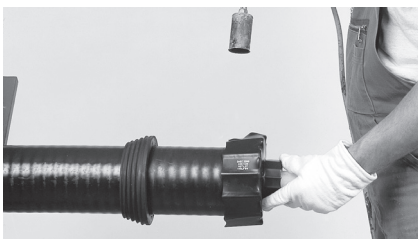

7 Carefully shrink on the pipe end closure according to the Raychem DHEC installation instruction.

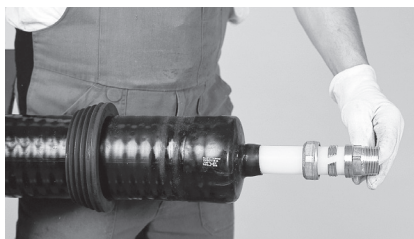

8 Install the fitting as per the enclosed installation instructions.

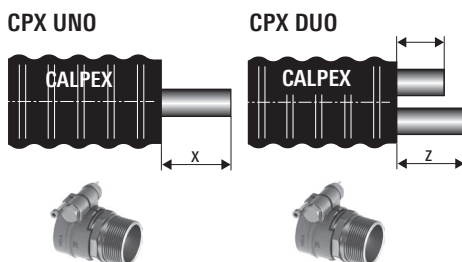

UNO screwed connector
House connection:
ø 20 - 75 X = 90 mm
ø 90 - 110: X = 110 mm

DUO screwed connector
House connection:
ø 20 - 75: Y = 80 mm
ø 20 - 75: Z = 180 mm

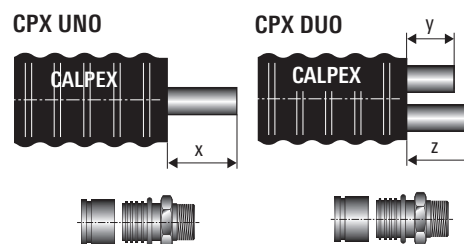

UNO compression joint
House connection:
ø 20 - 50: X = 140 mm
ø 63 - 125: X = 180 mm
Joint/sleeve:
ø 20 - 50: X = 110 mm
ø 63 - 110: X = 140 mm
ø 125 - 160: X = 150 mm

DUO compression joint
House connection:
ø 20 - 50: Y,Z = 140 mm
ø 63 - 75: Y,Z = 160 mm
Joint/sleeve:
ø 20 - 50: Y,Z = 110 mm
ø 63 - 75: Y,Z = 140 mm

Note: Install the CPX-Clip-Shells according to the installation instruction!

Installation tools

general and for screwed connector

Cut to length and strip insulation

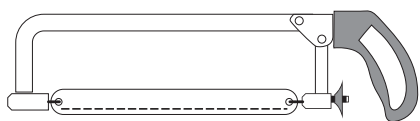

The saw is used to cut the casing pipe and the insulation

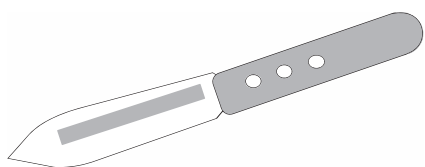

Knife to split casing and remove insulation

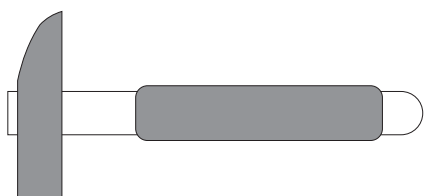

Hammer as auxiliary tool

Fit of connection piece

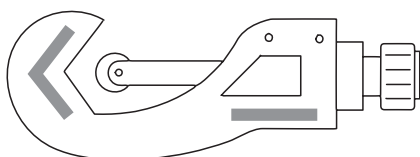

Pipe cutter for PEX pipe

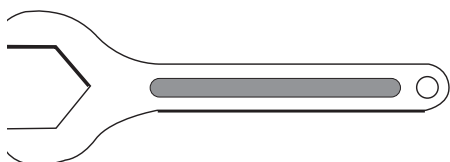

Spanner wrench

Shrink procedure

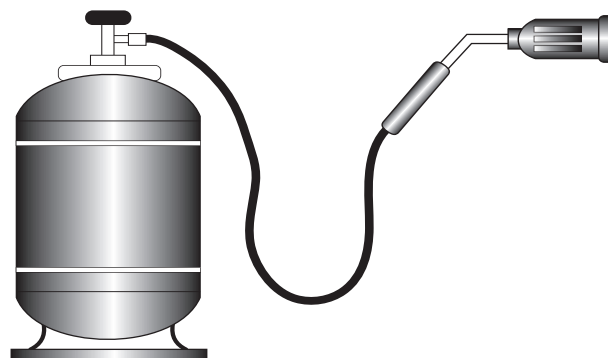

The gas burner is used to shrink hoses and joints

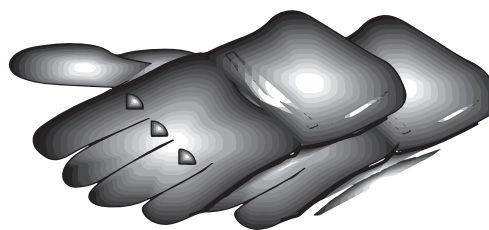

It is recommended that gloves are worn for shrinking work.

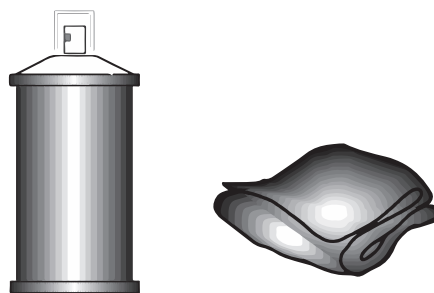

Cleaning products and cleaning cloths

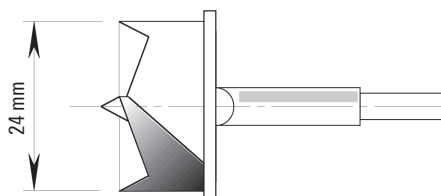

Flat bit for cutting filler hole

Installation tools

for press fit joints

Manual tool for PEX Ø 22 - 40 mm (packed in one case)

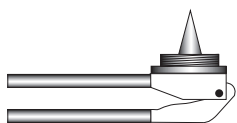

Expander tool, up to Ø 32 mm
(basic tool)

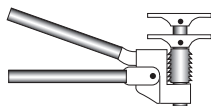

Press tool, up to Ø 40 mm
Expander tool for Ø 40 mm
(basic tool)

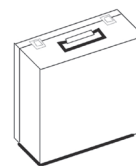

Case with basic tool
including head and yoke

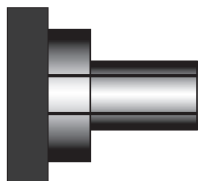

Expander head, up to Ø 32 mm

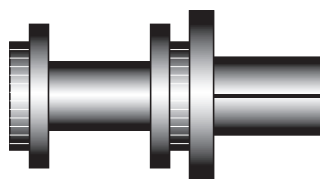

Expander head, over Ø 40 mm

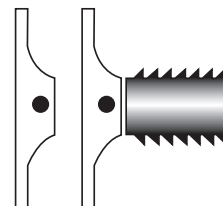

Press yoke, Ø 22 - 40 mm

Hydraulic tool for PEX Ø 50 - 110 mm (packed in two cases)

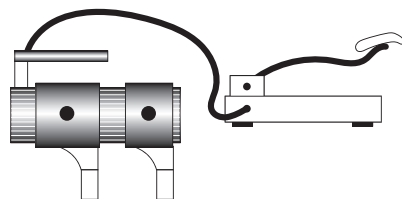

Hydraulic press and expander tool
Ø 50 - 110 mm including foot pump (basic tool)

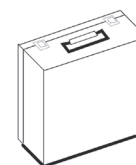

Case with basic tool
(without heads and yoke)

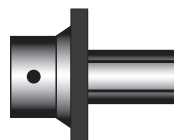

Expander head
Ø 50 - 110 mm

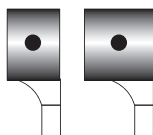

Press yoke
Ø 50, 63 mm

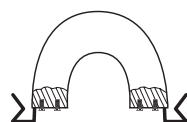

Reducer Ø 75/90 mm
for yoke, Ø 110 mm

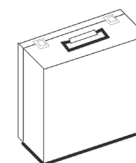

Case with expander heads
and press yoke

Electro-hydraulic tool for PEX Ø 125 - 160 mm (packed in two cases)

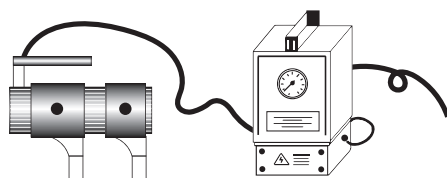

Hydraulic press and expander tool
Ø 125 - 160 mm including foot pump (basic tool)

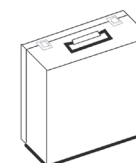

Case with basic tool
(without heads and yoke)

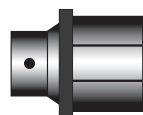

Expander head
Ø 125 - 160 mm

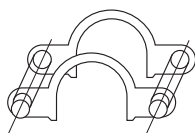

Press yoke
Ø 140 mm, 160 mm

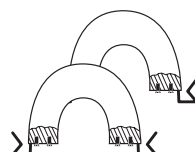

Reducer Ø 125 mm
for yoke, Ø 160 mm

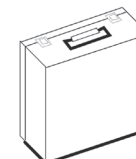

Case with expander heads
and press yoke

Heating strip, CALPEX SANITARY (Sanitary, 10 bar)

Drawing in, sensor, joint

1. Pulling through the heating strip

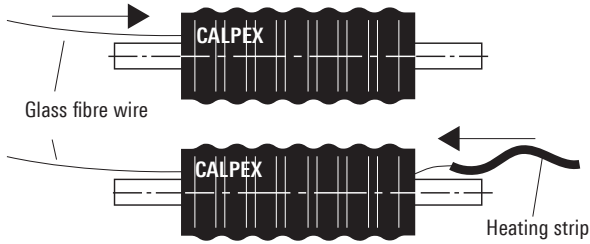

1. Unroll the pipe so that it is straight, next to the trench (without bends). See also CPX 1.120. Shorten the casing and cut back the channel. From one end, push the glass fibre wire (ø 6.5 mm) through the channel. The heating strip can be pushed in for straight lengths of up to 30 m.

2. Connect the heating strip or pull cord to the wire (drill a hole in the strip) and pull through the heating strip.

2. Installation of the temperature sensor for frost protection

The temperature sensor has to be installed on the carrier pipe, opposite the heating strip. It must be installed at the coldest point of the pipe (outside the building). For this purpose, cut open an area of the casing measuring 10 x 7 cm and peel it off, cut open 10 x 7 cm of foam, fix the temperature sensor onto the carrier pipe with adhesive tape, fill the hole with the insulation material supplied, apply filling adhesive S1113 below and above the temperature sensor cable (see Detail B), and seal with the sealing set.

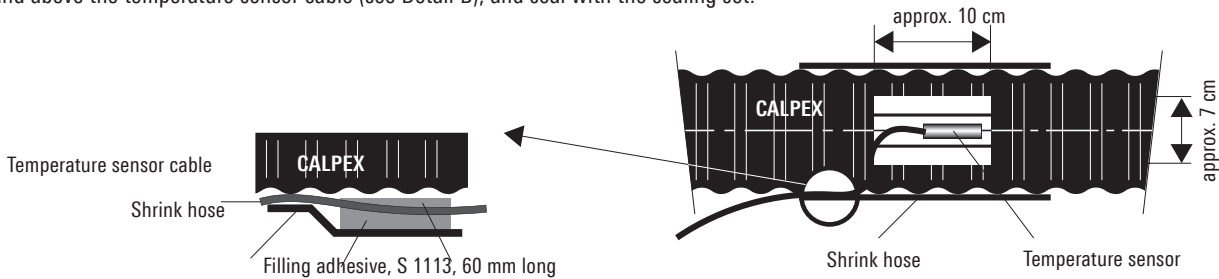

3. Remove the insulation

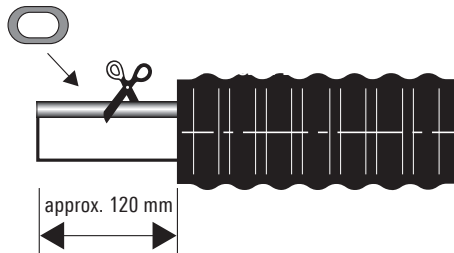

Shorten the casing by 120 mm and cut off the exposed channel.

4. Joint

Through connection $L \leq L_{max}^*$
Feed in from one end

Separate of heating strips $L > L_{max}^*$
Feed in from both end (each strip $\leq L_{max}$)

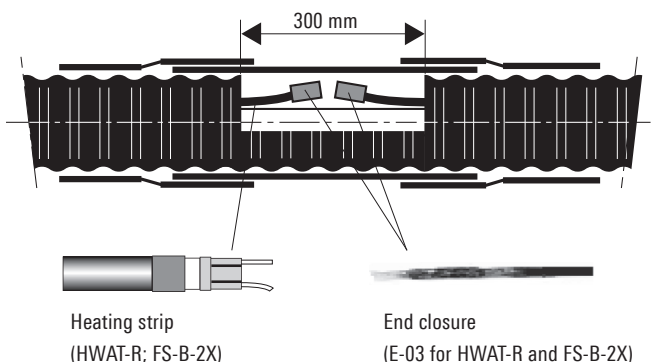
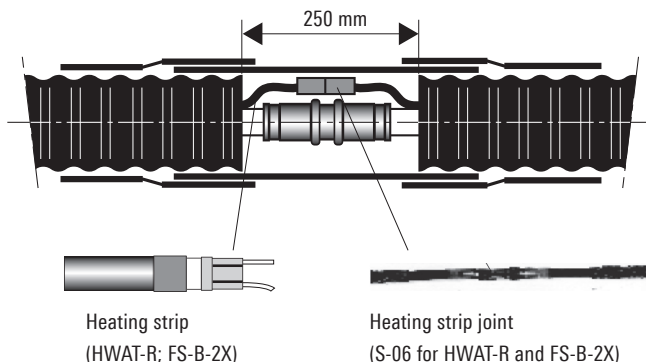

Protect the heating strip against moisture

* L_{max} = max. permitted length for heating strip

The heating strip and the accessories are supplied and installed by the electrician!